

Mechanical Fail-Safe Damper Actuator EF24A-S2



Spring return actuator with emergency function for adjusting air dampers in ventilation and air conditioning systems in buildings

- Torque 30Nm
- Nominal voltage AC/DC 24V
- Control: Open-close
- Two integrated auxiliary switches



Technical data

Electrical data	Nominal voltage	AC 24V, 50/60Hz / DC 24V		
	Nominal voltage range	AC 19.2...28.8V / DC 21.6...28.8V		
	Power consumption	In operation	9.5W @ nominal torque	
		At rest	4.5W	
		For wire sizing	16VA	
	Auxiliary switch	2 x SPDT, 1 x 10% / 1 x 11...90%		
Connection	Motor	Cable 1m, 2 x 0.75mm ²		
	Auxiliary switch	Cable 1m, 6 x 0.75mm ²		
Functional data	Torque	Motor	Min. 30Nm @ nominal voltage	
		Spring return	Min. 30Nm	
	Direction of rotation	Can be selected by mounting L / R		
	Manual override	With hand crank and interlocking switch		
	Angle of rotation	Max. 95°↔, can be limited with adjustable mechanical end stop		
	Running time	Motor	≤75s (0...30Nm)	
		Spring return	≤20s @ -20...50°C / max. 60s @ -30°C	
	Sound power level	Motor	≤55dB(A)	
		Spring return	≤71dB(A)	
	Service life	Min. 60,000 emergency positions		
	Position indication	Mechanical		
	Safety	Protection class	III Extra low voltage UL Class 2 Supply	
		Degree of protection	IP54	
			NEMA2, UL Enclosure Type 2	
		EMC	CE according to 2004/108/EC	
Low-voltage directive		CE according to 2006/95/EC		
Certification		Certified to IEC/EN 60730-1 and IEC/EN 60730-2-14		
		cULus according to UL 60730-1A and UL 60730-2-14 and CAN/CSA E60730-1:02		
Mode of operation		Type 1.AA.B		
Rated impulse voltage		Actuator	0.8kV	
		Auxiliary switch	2.5kV	
Control pollution degree		3		
Ambient temperature		-30...+50°C		
Non-operating temperature		-40...+80°C		
Ambient humidity		95% r.h., non-condensating		
Maintenance		Maintenance-free		
Dimensions / Weight	Dimensions	See «Dimensions»		
	Weight	Approx. 4.4kg		

Dimensions [mm]

Dimensional drawings

Damper spindle	Length	○ I	■ I	◇ I
	≥117	12...26.7	>12	< 25.2
	≥20	12...26.7	>12	< 25.2

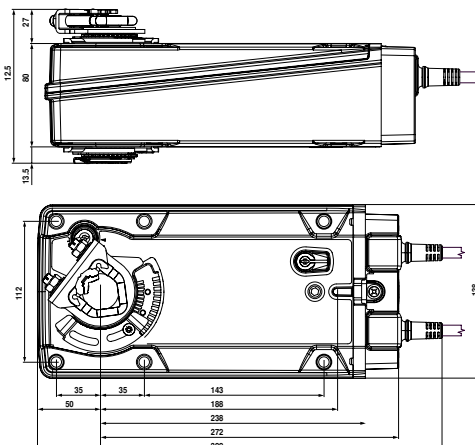
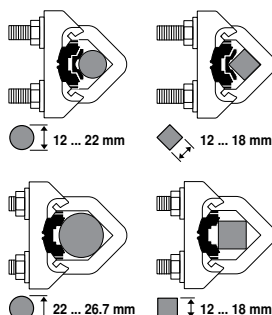

Modulating spring return actuator with emergency function for adjusting air dampers in ventilation and air conditioning systems in buildings

- Torque 30Nm
- Nominal voltage AC/DC 24V
- Control: modulating DC (0)2...10V
- Position feedback DC 2...10V



Technical data

Electrical data	Nominal voltage	AC 24V, 50/60Hz / DC 24V
	Nominal voltage range	AC 19.2...28.8V / DC 21.6...28.8V
	Power consumption	In operation 7W @ nominal torque At rest 4.5W For wire sizing 12VA
	Connection	Cable 1m, 4 x 0.75mm ²
Functional data	Torque	Motor Min. 30Nm @ nominal voltage Spring return Min. 30Nm
	Control	Control signal Y DC (0)2...10V, input impedance 100kΩ Operating range DC 2...10V
	Position feedback (measuring voltage U)	DC 2...10V, max. 0.5mA
	Position accuracy	±5%
	Direction of rotation	Motor Reversible with switch ↻ / ↻ Spring return Can be selected by mounting L / R
	Manual override	With hand crank and interlocking switch
	Angle of rotation	Max. 95°↺, can be limited with adjustable mechanical end stop
	Running time	Motor 150s (0...30Nm) Spring return ≤20s @ -20...50°C / max. 60s @ -30°C
	Sound power level	Motor ≤45dB(A) @ 150s running time Spring return ≤71dB(A)
	Service life	Min. 60,000 emergency positions
	Position indication	Mechanical
	Safety	Protection class
Degree of protection		IP54 NEMA2, UL Enclosure Type 2
EMC	Certification	CE according to 2004/108/EC Certified to IEC/EN 60730-1 and IEC/EN 60730-2-14 cULus according to UL 60730-1A and UL 60730-2-14 and CAN/CSA E60730-1:02
	Mode of operation	Type 1.AA
	Rated impulse voltage	0.8kV
	Control pollution degree	3
	Ambient temperature	-30...+50°C
	Non-operating temperature	-40...+80°C
	Ambient humidity	95% r.h., non-condensating
	Maintenance	Maintenance-free
Dimensions / Weight	Dimensions	See «Dimensions»
	Weight	Approx. 5.3kg

Dimensions [mm]

Dimensional drawings

Damper spindle	Length	⊙ I	■ I	◇ I
	≥117	12...26.7	>12	< 25.2
	≥20	12...26.7	>12	< 25.2

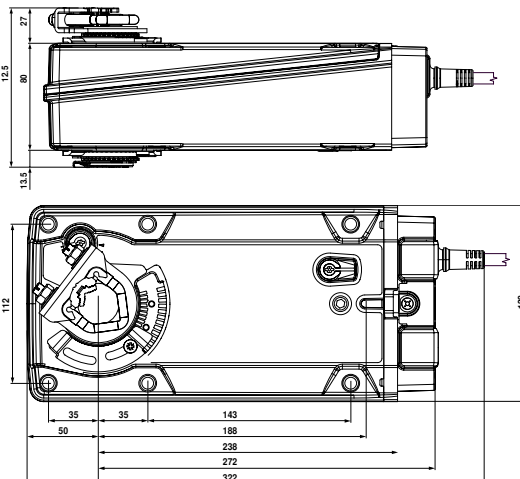
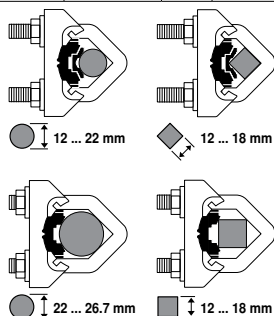

Mechanical Fail-Safe Damper Actuator EF230A-S2



Spring return actuator with emergency function for adjusting air dampers in ventilation and air conditioning systems in buildings

- Torque 30Nm
- Nominal voltage AC 230V
- Control: Open-close
- Two integrated auxiliary switches



Technical data

Electrical data	Nominal voltage	AC 230V, 50/60Hz	
	Nominal voltage range	AC 90...264V	
	Power consumption	In operation	9W @ nominal torque
		At rest	4.5W
	For wire sizing	21VA	
	Auxiliary switch	2 x SPDT, 1 x 10% / 1 x 11...90%	
	Connection	Motor	Cable 1m, 2 x 0.75mm ²
		Auxiliary switch	Cable 1m, 6 x 0.75mm ²
Functional data	Torque	Motor	Min. 30Nm @ nominal voltage
		Spring return	Min. 30Nm
	Direction of rotation	Can be selected by mounting L / R	
	Manual override	With hand crank and interlocking switch	
	Angle of rotation	Max. 95°↔, can be limited with adjustable mechanical end stop	
	Running time	Motor	≤75s (0...30Nm)
		Spring return	≤20s @ -20...50°C / max. 60s @ -30°C
	Sound power level	Motor	≤56dB(A)
		Spring return	≤71dB(A)
	Service life	Min. 60,000 emergency positions	
	Position indication	Mechanical	
	Safety	Protection class	II Totally insulated <input type="checkbox"/>
Protection mode		IP54	
		NEMA2, UL Enclosure Type 2	
EMC	CE according to 2004/108/EC		
Low-voltage directive	CE according to 2006/95/EC		
Certification	Certified to IEC/EN 60730-1 and IEC/EN 60730-2-14 cULus according to UL 60730-1A and UL 60730-2-14 and CAN/CSA E60730-1:02		
	Mode of operation	Type 1.AA.B	
	Rated impulse voltage	Actuator	2.5kV
		Auxiliary switch	2.5kV
	Control pollution degree	3	
	Ambient temperature	-30...+50°C	
	Non-operating temperature	-40...+80°C	
	Ambient humidity	95% r.h., non-condensating	
	Maintenance	Maintenance-free	
Dimensions / Weight	Dimensions	See «Dimensions»	
	Weight	Approx. 5.4kg	

Dimensions [mm]

Dimensional drawings

Damper spindle	Length	○ I	□ I	◇ I
	≥117	12...26.7	>12	<25.2
	≥20	12...26.7	>12	<25.2

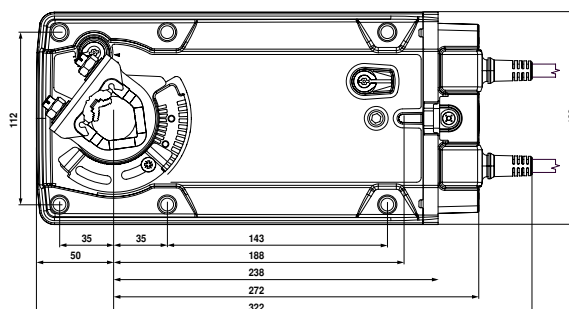
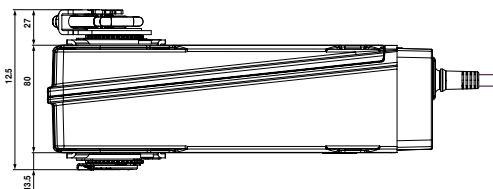
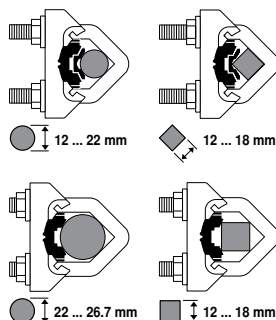

Wiring diagrams: Open/Close actuators

Notes:

- Parallel connection of several actuators is possible.
- Power consumption must be observed.

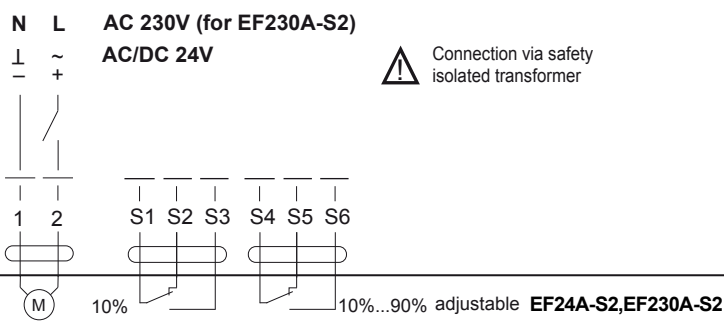
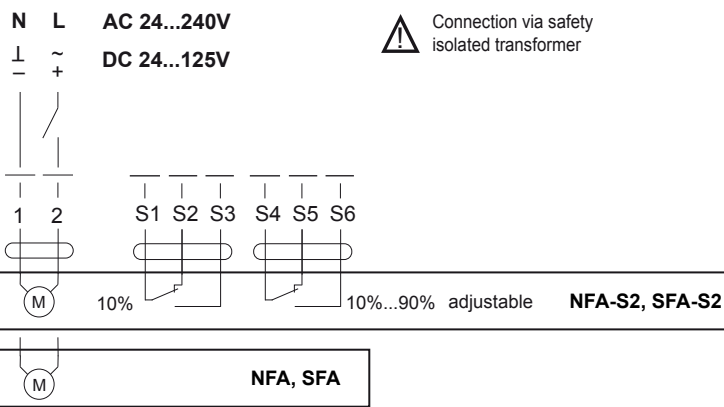
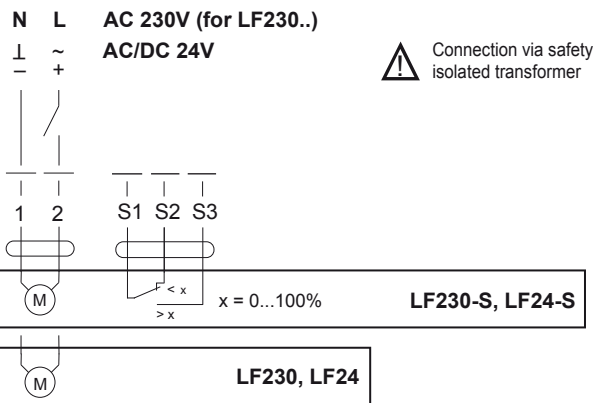
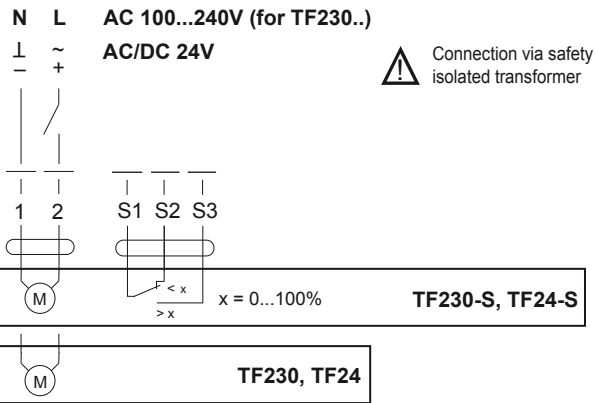

Wiring diagrams: 3-point actuators

Notes:

- Connection via safety isolating transformer.
- Parallel connection of several actuators is possible.
- Power consumption must be observed.

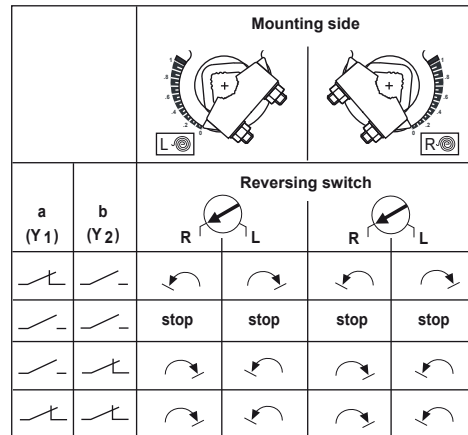
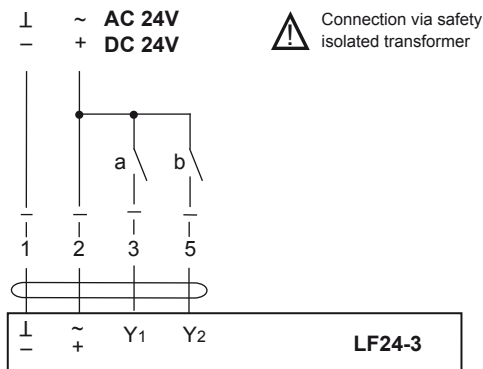
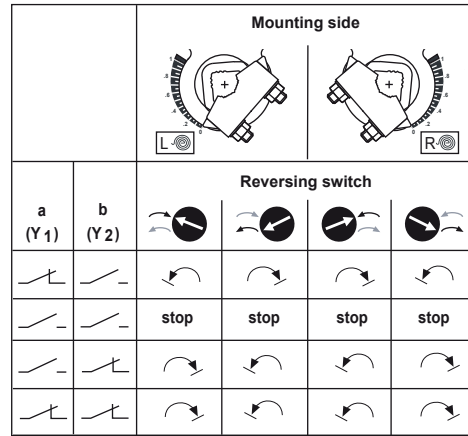
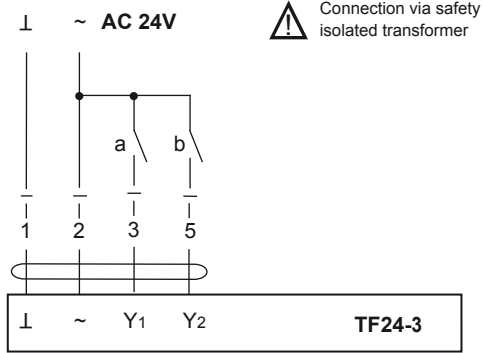

Wiring diagrams: modulating actuators

Notes:

- Connection via safety isolating transformer.
- Parallel connection of several actuators is possible.
- Power consumption must be observed.

