

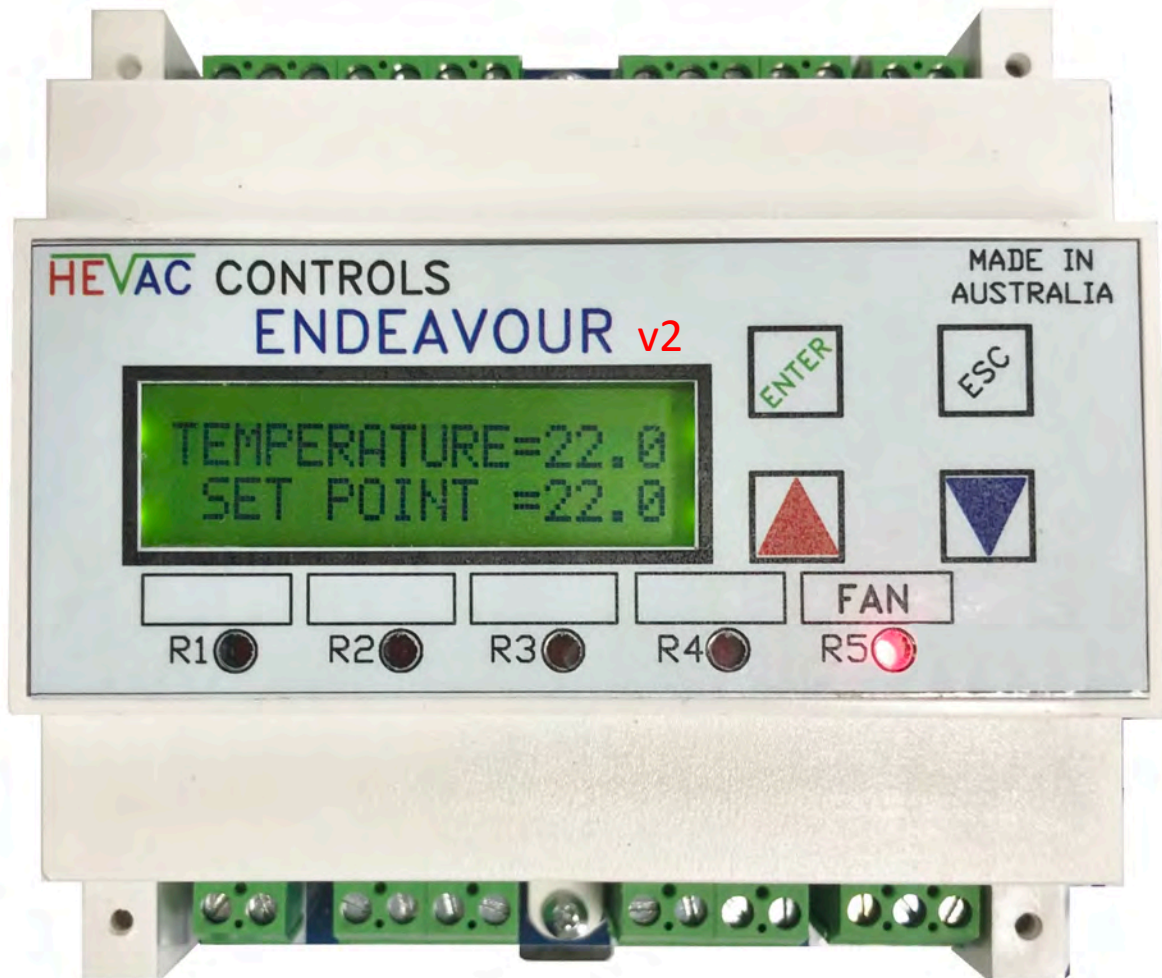

## ENDEAVOUR v2 USER MANUAL



### V2 NEW FEATURES

- 1.) ADDED INDEPENDENT AUXILIARY TIME SWITCH
- 2.) EVENT DATA LOGGER
- 3.) FAN RELAY (R5) SETTABLE AS CONTINUOUS OR CYCLE
- 4.) ADJUSTABLE MIN. / MAX SETTINGS FOR Y1 & Y2 0-10v O/P's
- 5.) SUPPLY AIR TEMPERATURE SENSOR MONITORING INPUT
- 6.) EXTERNAL A/C FAULT (D3) & AUX I/P (D4) BMS MONITORING INPUTS
- 7.) ACTIVE 0-10vdc SENSORS NOW SCALABLE
- 8.) ADDED CO2 ON/OFF RELAY CAPABILITY CONTROL.
- 9.) CAN BE SET TO TIME SWITCH **ONLY** MODE (-NO TEMP. CONTROL)
- 10.) LOCKABLE 3 LEVEL MENU & SETPOINT ACCESS
- 11.) RECLAIM LOCAL SETPOINT CONTROL FROM REMOTE FOR SERVICE
- 12.) FURTHER ENHANCEMENTS TO HMI CONTROL OF ENDEAVOUR

<b>INDEX</b>	<b>PAGE</b>
BASIC OVERVIEW, OVERRIDES & I/O USAGE.....	3
TECHNICAL NOTES .....	4, 5
USER INTERFACE & KEYBOARD LOCK LEVELS.....	6
MENU DESCRIPTION .....	7
CLOCK SETUP - TIME, DATE & DAYLIGHT SAVING ENABLE.....	8
SET (A/C SYSTEM) "START BY" METHOD.....	9
MAIN TIME SWITCH (1) .....	10
AUXILLARY TIME SWITCH (2) .....	11
RUN / AHR TIMER .....	12
HOLIDAY OFF OVERRIDE.....	12
EVENT HISTORY DATA LOGGER .....	13
RELAY 1-4 ASSIGNMENT & PARAMETER PROGRAMMING.....	13,14
RELAY 5 FAN CONTROL METHOD (CONTINUOUS OR CYCLE).....	15
Y1 & Y2 ANALOGUE OUTPUT PROGRAMMING.....	15,16
X1 MAIN TEMP. SENSOR CONFIGURATION.....	17
X2 REMOTE SET POINT CONFIGURATION.....	17
X3 OUTSIDE AIR TEMP. SENSOR CONFIGURATION.....	18
X4 AUXILIARY TEMPERATURE (MEASUREMENT ONLY) SENSOR.....	19
INPUT PASSIVE OR ACTIVE HARDWARE SETTINGS.....	19
X7 CO2 SENSOR ENABLE & Y1 ECON.CYCLE OVERRIDE SETTINGS.....	20
NIGHT PURGE VENTILATION SETUP.....	21
MODBUS SETUP & MEMORY MAP.....	22
CONTROLLER MAIN MODE OF OPERATION - T/SW. OR TEMP CONTROL.....	23
FACTORY DEFAULTS.....(also see page 25).....	23
TYPICAL CONNECTIONS & EXTERNAL INTERLOCKS OVERVIEW.....	24
USER PROGRAM INFORMATION FORMS.....	25-27
SITE & SYSTEM NOTES (blank page).....	28

- The Hevac ENDEAVOUR is a fully programmable microprocessor based Temperature (+ CO2) controller, with optional use of an internal 365 day Time Switch, an independent Auxiliary Time Switch and a Run Timer all in the one model. The controller has 7 analogue inputs, 4 digital inputs, 5 relay outputs and 2 analogue (0-10vDC) outputs. Controller I/O, time & date etc. is displayed via a backlit LCD screen giving plain English status information together with 5 dedicated LED's showing the relays on/off state. The controller is primarily intended for Air Conditioning temperature control applications where On/Off control of Heating and Cooling stages and /or modulating P+I control of actuators / devices requiring a variable 0-10vdc control signal is required. Typically used to control DX Air Conditioning units, Electric heating stages, modulating Heating & Cooling Valves, VSD's & Economy Cycle Damper sets etc. Note with this latest software version, the Endeavour can now also be set to "Time Switch only" mode with all other none timer capabilities disabled allowing this module to be used as a 2 channel 365 day Time Switch or Run Timer only.
- Four of the five relays are programmable for their mode of operation ie :Heat, Cool or Both (both means the relay operates as both a heating and cooling stage), and also new to this version, relays can now be programmed as On/Off CO2 stages **or** as an extra independent Auxiliary Time Switch. The relay program menu allows individual settings of mode, deadbands, switching differentials & time delays. The 5th relay is dedicated as a System Run (Fan / Main Time Switch) relay which can now also be set to operate continuously whilst the controller is enabled or to **cycle** on & off with the compressor (which is typical for domestic A/C systems). The two available Analogue 0-10vDC output signals can be individually programmed for Mode of operation (heat /cool or both), start point (deadband), range (proportional band) & method of control (P or P+I) plus also new to this version the minimum & maximum "Y" output 0-10vdc signals can now be range limited, with any minimum value setting automatically overridden to zero when the system is off, which is perfect for EC fan time switch control with a minimum speed requirement.

## **EXTERNAL OVERRIDES & OPTIONAL CONNECTIONS**

- The controller has **Modbus** communications capability for connecting of up to 32 controllers to our HMI colour wall display panel for zone status, individual setpoint adjustment & system Auto/Off/On override. Alternatively upto 247 controllers can be connected to a 3rd party BMS system for remote control & monitoring. For added BMS monitoring, analogue input "X4" can be used to measure an auxiliary temperature (typically the supply air temperature), "D3" is a dedicated A/C fault monitoring input & "D4" is a general purpose on/off status input that could be used for example to monitor & prove supply air fan running operation via a mechanical pressure switch.
- Remote System **AUTO/OFF & AHR** operation can be easily added by simply connecting a normally open (N/O) switch anywhere convenient in parallel with the main temperature sensor wires X1 & M. Momentarily shorting X1 & M results in triggering a run timer function (typically as an after hours timer function) or / & constant shorting of X1 & M results in a system **OFF** function. These functions are also duplicated on the controller terminals "D1 & M" for AUTO/OFF & AHR operation, plus connecting a switch to "D2 & M" sets a forced manual Time switch "24/7 **ON**" override.
- With an optional **O/A sensor** connected, the Economy cycle damper operation (Y1 output) for temperature control can be interlocked for free heating, cooling or both when the outside air temperature conditions are favorable. The fresh air sensor (X3) is compared to the room (or return air) temperature sensor (X1), & if the outside air temperature is measured to be more suitable for free temperature control the motorized damper output signal (Y1) will modulate to F/A mode per room temperature demand. The use of outside air for temperature control can also be inhibited if the outside air temperature falls below an adjustable minimum O/A temperature (factory set at 16C for DX or FCU coil protection ).
- With an optional **CO2 sensor** connected, economy cycle dampers can also be proportionally driven to the fresh air mode to reduce high CO2 levels. The maximum damper output signal for CO2 control can be restricted in extreme O/A temperatures so as not to lose temperature control, all settings are user adjustable. The CO2 input can now also control relays for on/off CO2 control.
- **Remote Set Point** devices (either passive or active) can be connected to the controller. If a passive adjuster is connected (default setting), the controller will automatically detect and hand over set point adjustment authority to the remote device (then ignoring the controllers UP & DOWN buttons for set point adjustment). The remote set point potentiometer can be built into a room temperature sensor (SRT-DSP) or as a separate stand alone device giving remote setpoint control only (SPA-D). The range of the passive remote setpoint is fixed at 18 to 25 degrees over 0 to 10K. If an active remote setpoint device is used the 0-10vDC is +/-5c adjustable for 0v & the top end range adjustable upto 100c. Also new : Any remote setpoint device can now be temporarily virtually disconnected by holding the UP & DOWN buttons together for 5 seconds which hands conventional setpoint control back to the controller to aid in commissioning & testing, but will automatically reset to remote control after 10 minutes or can be canceled anytime by again pushing the UP & DOWN buttons together.

## Technical Data

### General Specifications

---

Operating Voltage	12 to 24 Volts AC or DC
Power Consumption	
At 24vDC Volts	200mA
At 24vAC Volts	5 VA
Switching Capacity of Relays	
Voltage	AC 0...250 Volts
Current	8.0 (2.5) Amps
Set point Setting Range	5-35 oC in 0.1 oC Increments
Relay Switch ON Points (Dead band)	0.1-19.9 oC
Relay Hysteresis (Switching Differential)	0.1-9.9 oC
Relay to Energise Time Delay	0.1-42 Minutes
Y1/Y2 Output Voltage Range	0-10VDC ( NOTE MINIMUM & MAXIMUM Y OUTPUT VOLTAGE USER ADJUSTABLE )
Y1/Y2 Start Point (Dead band)	0-19.9 oC
Y1/Y2 Range (Proportional Band)	0.5-25 oC
Y1/Y2 Integral action (P+I triggers >10% P output)	Off-60 minutes

---

#### ANALOG INPUTS

- X1 : Main Temperature Sensor Input configurable (with jumper & software) as Active (0-10vdc ~0 to 100c (adjustable) or Passive (4.2k@22c).
- X2 : Remote Set point configurable (with jumper & software) as passive using 10K Potentiometer (18-25c Range) or 0-10vdc (top end range configurable).
- X3 : Outside temperature sensor configurable (with jumper & software) as Active (0-10v~0-100c) or Passive (4.2k@22c).
- X4 : Auxiliary Measurement Temperature Sensor, Input configurable (with jumper) as Active (0-10vdc ~0 to 100c (adjustable) or Passive (4.2k@22c).
- X7 : Room or R/A Duct CO2 Sensor input to override economy cycle operation or to control internal relays (R1-4) not used for temperature control.
- 

#### Output Indication

Relay On/Off Status	5 x Red LED
LCD Display	2 x 16 character LCD
Display Resolution	0.1 Increments

---

#### Communication :

Terminal's X5 & X6 configurable as RS485 MODBUS Outputs

X7 can be set to ground (via a 100 ohm resistor) for use as a comms shield connection if not used as a CO2 sensor connection.

## Technical Data (Cont.)

Environmental Conditions	Operation	
	Ambient Temperature	0...45oC
	Humidity	< 85 % RH (Non Condensing)
	Storage and Transport	
	Ambient Temperature	-5...65oC
	Humidity	< 90 % RH (Non Condensing)
Product Standards	COMPLIES TO ALL RELEVANT AUSTRALIAN STANDARDS including 6mm segregation between high & low voltage connections	
Weight	Including Packaging	600 grams
Housing	Colour	Grey
	Material	ABS POLYCARB
	UV Stabilised	YES
	Fire Retardant	YES
	Size	L105mm x W105mm x D60mm
	Mounting Method	35mm Din Rail Mountable

## Terminal Designations

X1	Main Temperature Sensor Input (Passive or Active)	M	Common sensor & signal ground
X2	Remote S/P input (Passive or Active) (Optional connection)	D1	Manual System OFF <b>&amp;/or</b> AHR trigger input
X3	O/A sensor input (Passive or Active) (Optional connection)	D2	Manual System ON Override (T/Sw. override)
X4	Auxiliary Temperature measurement sensor.	D3	External FAULT I/P (for indication)
X5	MODBUS RS485 - A Terminal	D4	External On/Off status I/P for BMS monitoring
X6	MODBUS RS485 - B Terminal	E & M	future Expansion module local comms.
X7	CO2 sensor (default) or MODBUS SHIELD (GND)		

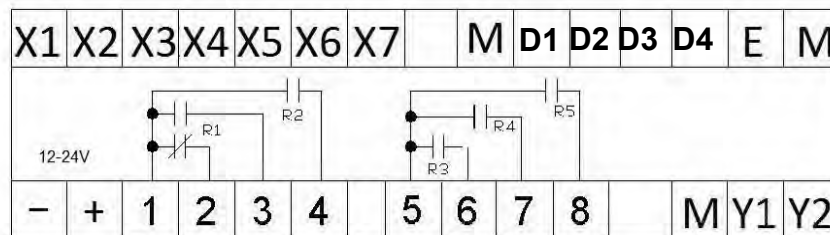

-	12-24 Volt Supply Neutral (internally connected to terminals M)	5	Relay 3,4 & 5 Common
+	12-24 Volt AC or DC Supply Active	6	Relay 3 Normally Open
	1	7	Relay 4 Normally Open
	2	8	Relay 5 Normally Open (FAN)
	3	M	Signal ground
	4	Y1	Analog Modulating Output 0-10 vDC
		Y2	Analog Modulating Output 0-10 vDC

The controllers face plate has four push buttons to access & edit controller settings.

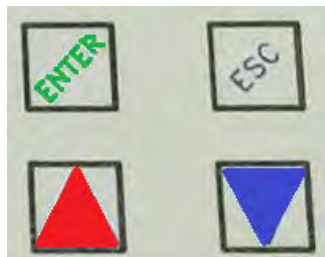

“ENTER” ACTS AS THE SAVE OR MENU OPEN BUTTON

“ESC” ACTS AS THE EXIT OR JUMP BACK TO PREVIOUS MENU BUTTON

“UP & “DOWN” BUTTONS ADJUST SETPOINT, SCROLL MENUS & TO EDIT VALUES.

The controller has a backlit (16x2) LCD screen & 5 red LED's to give controller input & output status. The LCD screen will automatically cycle through relevant screens displaying applicable information as per the users programmed use of the controller ie : Room Temperature, Setpoint, System “On By”, Time & Date, Analogue Output Values, Outside Air Temperature, CO2 ppm levels, Supply Air temperature, analogue output levels etc.

To access the menu list as shown on page 7, press the **ENTER** button & use the **UP** & **DOWN** arrow buttons to scroll through the menus, pressing **ENTER** to open a particular menu to edit. The relay assignments are user programmable and as such the relay “use identifier” text box above each LED is not factory marked and is for optional labeling by the commissioning technician. The factory default settings for these relays, from left to right is : COMP3, COMP2, COMP1, R/V HEAT, FAN, but could for example be assigned and marked as per the labeling shown bottom of this page. The analogue outputs Y1 & Y2 if used, are shown as a LCD display screen.

The keyboard can be set in three **lock levels**, level 0 is unlocked, level 1 allows setpoint adjustment only, level 2 allows no adjustment. To access the lock levels press & hold all four button for 5 seconds & release to display the existing level, adjust using the **UP** or **DOWN** arrow buttons and press the **ENTER** button to set & return to the running screen.



The LCD screens will automatically cycle through each relevant display.

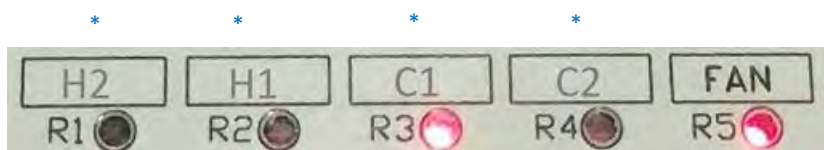

*\* example of optional identification of output relays by installation contractor*

# PROGRAM MENUS

## MENU

## FUNCTION

- 
- Set CLOCK** : TO SET THE CONTROLLERS TIME, DATE AND ENABLE DAY LIGHT SAVING
- Set "START BY" METHOD** : SET SYSTEM ON/OFF OPERATION "BY" the internal **TIMESWITCH (1)**, Internal **RUN TIMER** (Triggered by remote push button) or by a remote **MANUAL ON / OFF SYSTEM SWITCH** (by shorting out sensor X1 & M wires or D1 & M terminals).
- SET MAIN TIME SWITCH (1)** : PROGRAM MAIN (SYSTEM) TIME SWITCH (1) DAYS & ON OFF TIMES .
- SET AUX. TIME SWITCH (2)** : PROGRAM AUXILIARY INDEPENDENT 7 DAY TIME SWITCH (2) ON & OFF TIMES.
- SET RUN / AHR TIMER PERIOD** : SET RUN TIMER DURATION FOR USE AS AN AFTER HOURS RUN TIMER OR AS A SYSTEM RUN (FOR) TIMER ( with or without use of the main time switch ).
- SET HOLIDAYS** : PROGRAM INDIVIDULE OR GROUP HOLIDAYS SYSTEM OFF OVERRIDE DATES.
- VIEW EVENT HISTORY** : VIEW "ON" EVENT HISTORY - DATE , TIME & EVENT.
- R1-4 RELAY PROGRAMMING** : SET MODE & SETTINGS FOR THE 4 PROGRAMMABLE RELAYS (R1-4).
- \* **R5 FAN CONTROL METHOD** : PROGRAM R5 (FAN) TO CYCLE WITH HEAT / COOL CALL OR CONTINUOUS.
- Y1 & Y2 ANALOGUE PROGRAMMING** :SET MODE & SETTINGS FOR THE 2 PROGRAMMABLE ANALOGUE (Y1 & Y2) O/P's
- \* **X1 SENSOR CONFIGURATION** : SET MAIN CONTROL SENSOR (WHICH RELATES TO THE CONTROLLERS SETPOINT) AS ACTIVE or PASSIVE, CAL OFFSET & RANGE ADJUSTMENT.
- \* **X2 REMOTE S/P CONFIGURATION** : SET TYPE OF OPTIONALLY CONNECTED REMOTE SETPOINT AS PASSIVE 0-10K (FIXED RANGE OF 18-25C) or 0-10VDC (MAX RANGE ADJUSTABLE).
- \* **X3 O/AIR TEMP. SENSOR CONFIG.** : ENABLE & ADJUST SETTINGS FOR O/A TEMPERATURE SENSOR & ITS AFFECTS
- \* **X4 SUPPLY AIR SENSOR CONFIG** : ENABLE MONITORING (ONLY) OF AN AUX. SENSOR ..ie S/A TEMPERATURE.
- \* **X7 CO2 SENSOR CONFIGURATION** : ENABLE & ADJUST SETTINGS FOR A ROOM or (R/A DUCT) CO2 SENSOR
- \* **ENABLE NIGHT PURGE** : ENABLE & CONFIGURE TIME AND TEMP. CONDITIONS FOR NIGHT VENT MODE
- MODBUS SETUP** : ENABLE MODBUS & SET BAUD RATE & ADDRESS SETTINGS
- SET CONTROL APPLICATION** : SET ENDEAVOUR IN STANDARD TEMPERATURE. or TIME SWITCH ONLY MODE
- RESTORE FACTORY DEFAULTS** : CLEARS & RESETS ALL SETTINGS BACK TO FACTORY DEFAULTS
- EXIT MENU** : EXIT THIS MENU LIST AND RETURN TO OPERATING SCREENS
- \*these menu settings have no affect in TIME SWITCH ONLY application**





## SET \*START BY\* METHOD (A/C START / STOP CONTROL)

To set the A/C system "START BY" method, press the fascia button labeled "ENTER" then press the DOWN arrow button once to have the LCD display show the 2nd item in the menu tree (after SET CLOCK) : "SET START BY METHOD "

Press the ENTER button to open this menu & see the existing setting, use the UP & DOWN buttons to cycle through the 3 choices :

"MANUAL", "TIME SWITCH" or "RUN TIMER".

Select your choice by pressing the "ENTER" button. The display will then return to this parent menu. Exit to the normal running screens by pressing the "ESC" button or scroll to another main menu item to edit or check using the "UP" or "DOWN" arrow buttons.

- 1.) **MANUAL** - System ON/OFF state set only by an external "System Switch" or external interlock wired in parallel with the 2 sensor wires connected to our passive temperature sensor or alternatively shorting the controllers D1 & M terminals which has the same affect, results in a "System Off" mode, with all relays and analogue outputs de-energized, Opening the switch allows 24/7 operation until the switch or interlock is closed again.
- 2.) **TIME SWITCH** (1) System enabled by the controllers internal main 7 day Time Switch, which can be programmed for a total of 18 possible switching events for individual or groups of days (allowing multiple on/off times per day).
- 3.) **RUN (for) TIMER** System operation triggered by a momentary on/off pulse from a switch wired in parallel with the 2 (passive) sensor wires or across the controllers D1 & M terminals. Adjust the timer for the required time i.e. 8 hours.

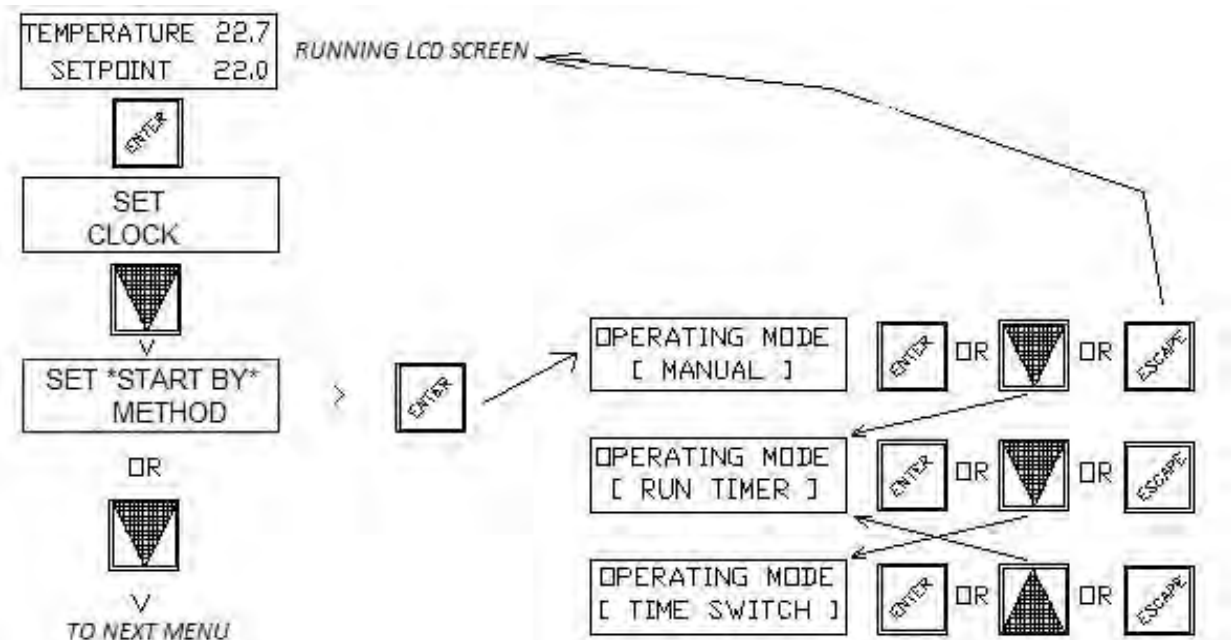

# SET MAIN TIME SWITCH (1)

The controller's internal main time switch (1) (if enabled for use) can be easily programmed for any combination of ON/OFF switching times for any day of the week. The controller comes preset with factory default settings for operating the system: Monday to Friday from 08:00 (event 01) until 17:30 (event 02). To edit settings, press the fascia button labeled "ENTER" and scroll down through the menu tree until "SET MAIN TIME SWITCH (1)" is displayed. Press the "ENTER" button to open this menu. The existing detail for switching event 01 is displayed. Unlike other time switches, this controller has very flexible unassigned switching events (instead of fixed sequential ON then OFF routines). Time switching events can be set to switch (change state) at any time & day/s, and set as a switching ON event or OFF event. Typically the switching events would be programmed in the order of ON events (with common days & time) followed by an OFF event with matching days and common OFF time, but any variation is easily programmed. As an example: switching events could be programmed such that switching event 1 (01) turns the system ON for Monday to Friday at 08:30, followed by event 2 (02) turning the system ON Saturday & Sunday at 09:00, then event 3 turning the system OFF Monday to Sunday at 17:30. With this programming approach, multiple & varied ON / OFF events can be set on individual or groups of days, plus there is no issue switching past midnight which most other time switches cant achieve. 18 switching events are available.

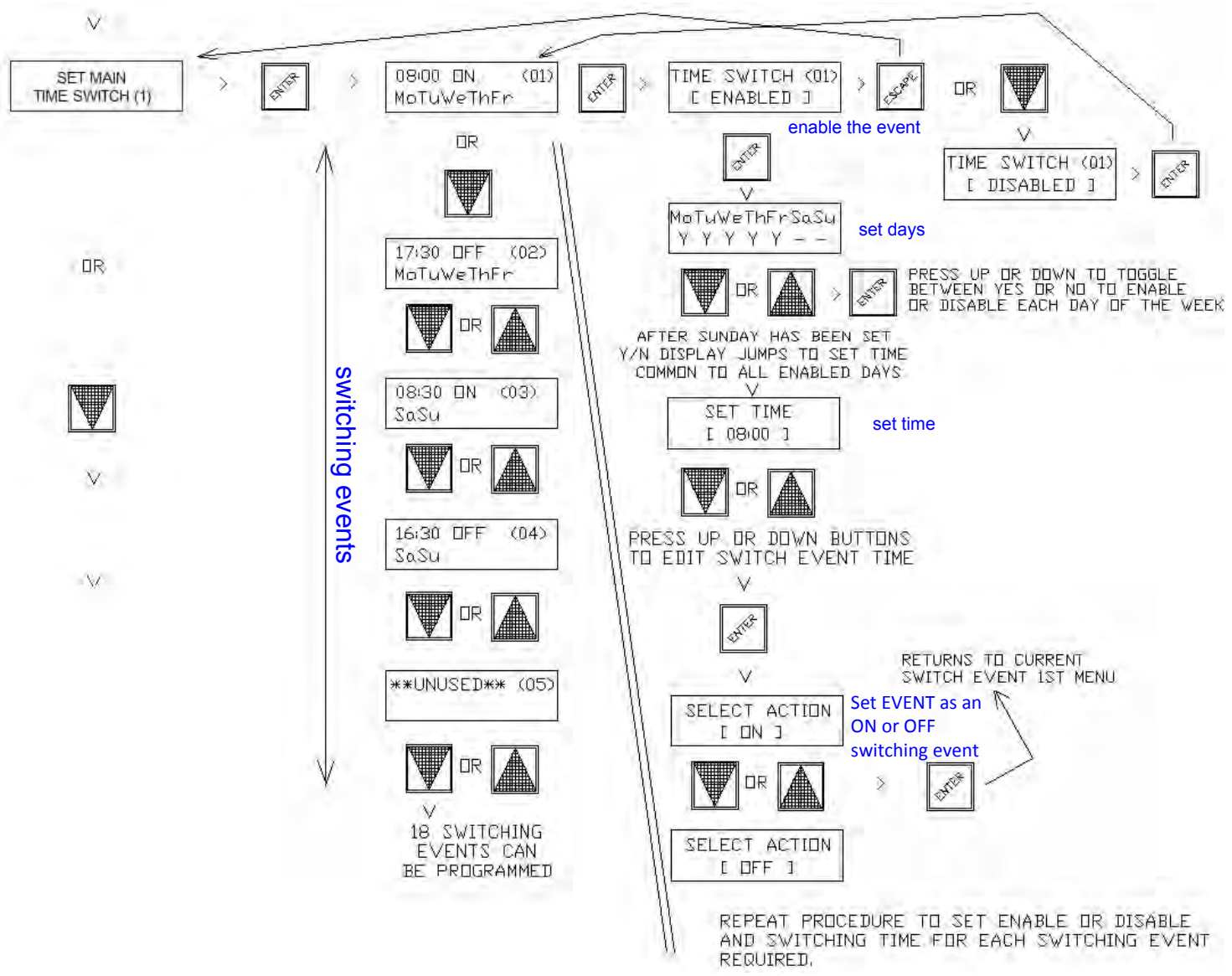

# SET AUXiliary TIME SWITCH (2)

The controller's independent Auxiliary Time Switch (2), if enabled for use, can be assigned to any spare relay not used as a Temperature or CO2 on/off control relay, and is assigned to a spare relay in the Relay Programming Menu. The Auxiliary Time Switch is basically intended as a simple auxiliary time switch for controlling other equipment not directly associated with temperature control ie : toilet exhaust fans etc, and is programmed using a more conventional time switch technique with programmable "ON" time events followed by "OFF" time events for the relevant days of the week. Note : This Auxiliary time switch has only two sets of ON & OFF settings (paired events) which would typically cover the separate on & off times for week days and weekends. To edit settings, press the fascia button labeled "ENTER" and scroll down through the menu tree until "SET AUX TIME SWITCH (2)" is displayed. Press the "ENTER" button to open this menu. If previously unused the 1st event (01) will display "\*\*\*UNUSED\*\*\*". Press the ENTER button to start editing. Press the UP button to change this event to "ENABLED" which is the 1st fixed "ON" event. Press ENTER which will then display an LCD screen to 'enable' the required days, use the UP / DOWN & ENTER buttons to sequentially set "Y" to all days that are to be enabled for this 1st (same) "ON" time (leave as "--" for disabled days). After Sunday is entered the display will jump to the "ON" time setting screen - use the UP / DOWN buttons to set the "ON" time, then press ENTER. The controller will then ask should this Auxiliary Time Switch be overridden (to OFF) by the programmed holidays ? (as set in the controllers "HOLIDAY" assignment menu), set "YES" or "NO" using the controller's UP / DOWN buttons and press ENTER. The display returns to this event screen (01). Press the DOWN arrow button to move to the next event screen (02) which is the 1st fixed "OFF" event setting screen, which is in respect to the previous "ON" setting -press ENTER. IF not already "ENABLED" press the DOWN arrow button to ENABLE this event, Press ENTER. Repeat the Y / -- setting for each day of the week which should be set to match the previous "ON" settings, then set the common "OFF" time for these days, press ENTER. Press the ESC button to exit Time Switch 2 programming if only one common on/off times for the week is required or press the DOWN arrow button until event (03) is displayed which is a 2nd (fixed as) 'ON' setting ~ Repeat the procedure per events (01) & (02) to set the ON (03) & OFF (04) times & days for these events. The Auxiliary Time Switch is now programmed, press "ESC" a few times to exit out to the main running screen.

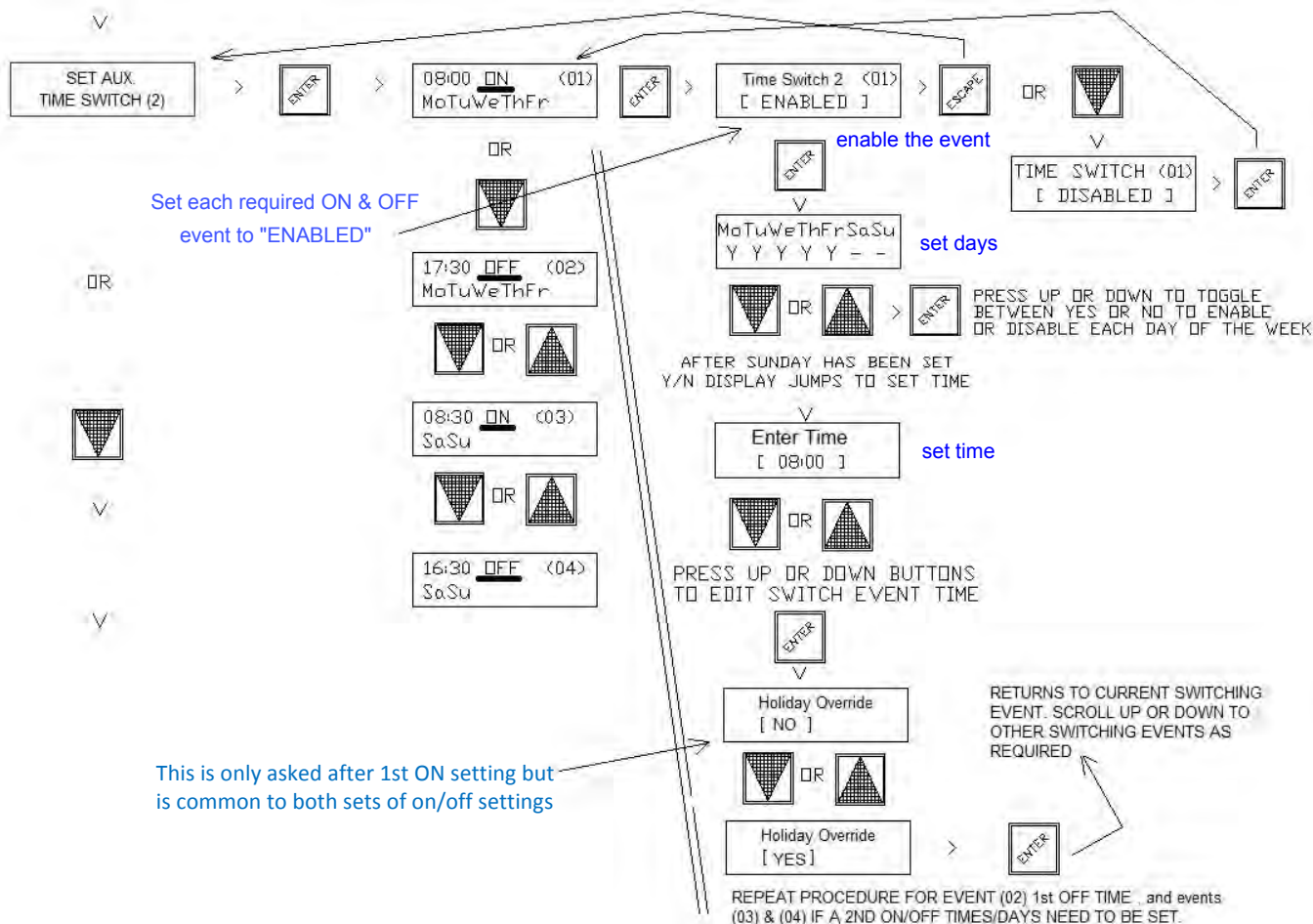

## RUN /AHR TIMER

Whether the Run Timer is used as a short duration type “After Hours”(AHR) Run timer (if the system normally operates by the controllers internal time switch), or set for a longer period, typically as a “Run For Timer”, the procedure to set up the timer is the same.

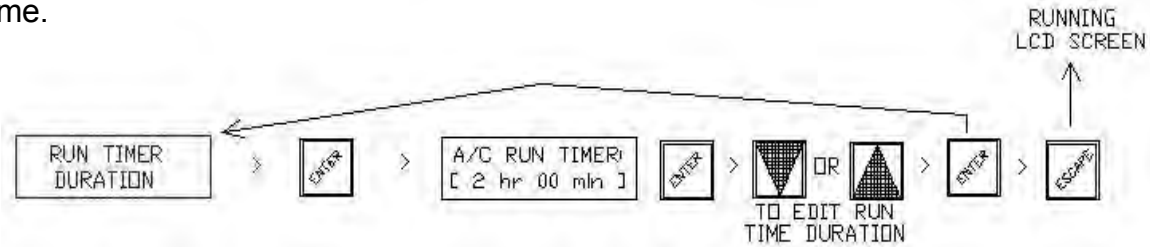

## LOAD HOLIDAYS (OFF OVERRIDE) SETUP

Individual or group of dates can be programmed as holiday time switch “OFF” overrides. To edit or set Holiday dates, Press the fascia button labeled “ENTER” to have the LCD display jump to the 1st menu item in the menu tree - “SET CLOCK” scroll down through the menu tree with the “DOWN” arrow button until “LOAD HOLIDAYS” is displayed. Pressing the “ENTER” button will then display either the 1<sup>st</sup> existing Holiday date or HOLIDAY DISABLED. If disabled, press the “DOWN” button to change to ENABLED. Once enabled, the 1st holiday default start date of 1<sup>st</sup> JAN (01) will be displayed, (01) means the 1st holiday. Using the “UP or DOWN” buttons scroll through calendar dates until the required 1st HOLIDAY START date is displayed, press “ENTER” to then also program the 1st HOLIDAY END date which can either be the same as the start date (if a single day holiday) or a future inclusive date for a group of days (i.e.: Easter or a school holiday term break). The controller asks after each holiday is set whether this holiday OFF override event should only execute once or repeat each year on the same date(/s), set as either ONCE or REPEAT using the “UP” or “DOWN” buttons, press “ENTER” to accept settings then the “DOWN” button to jump to the next holiday start date to program. Repeat this procedure until all holiday dates are set.

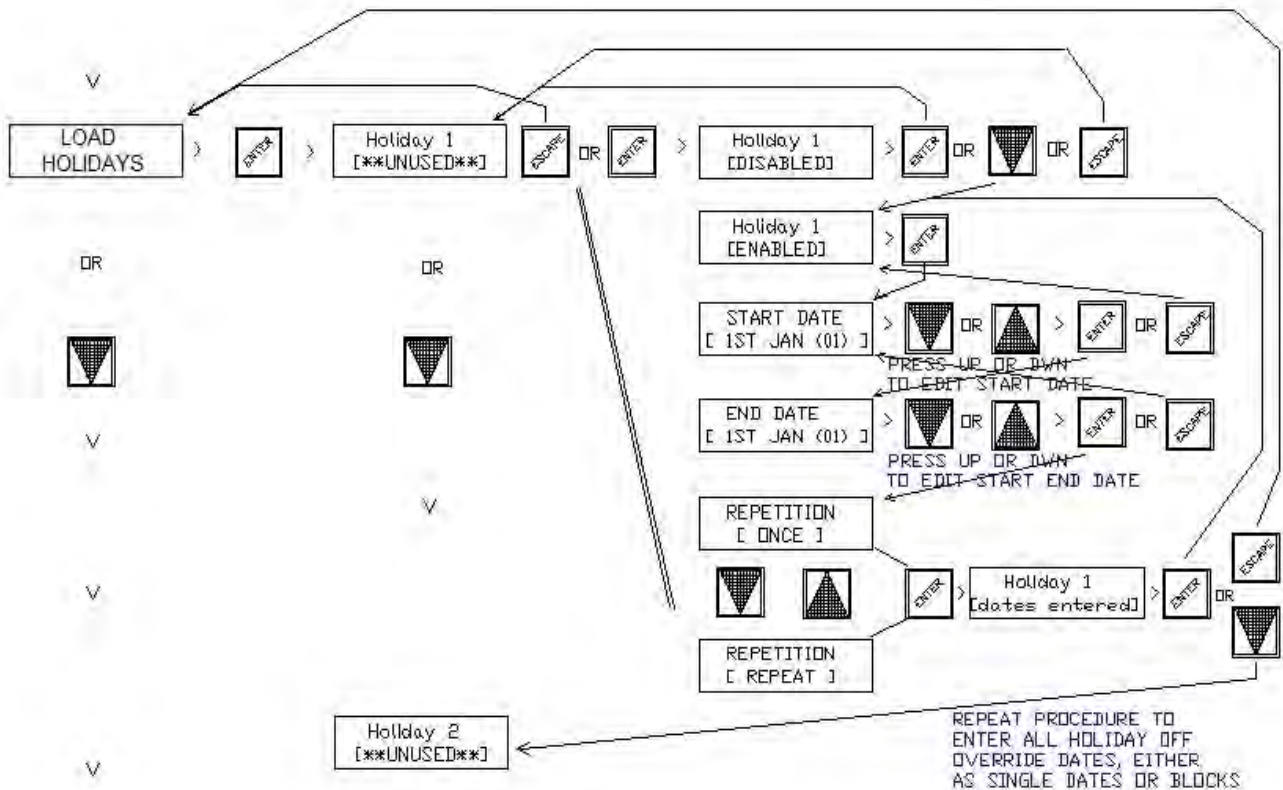

## VIEW EVENT HISTORY

This latest version of the ENDEAVOUR now incorporates a basic event logger that records the last 7 "ON" switching events.

example 01 : RELAY 3 ON 15/10/2019 16:30  
 02 : RELAY 2 ON 15/10/2019 16:50  
 03 : NIGHT PURGE ON 16/10/2019 04:35

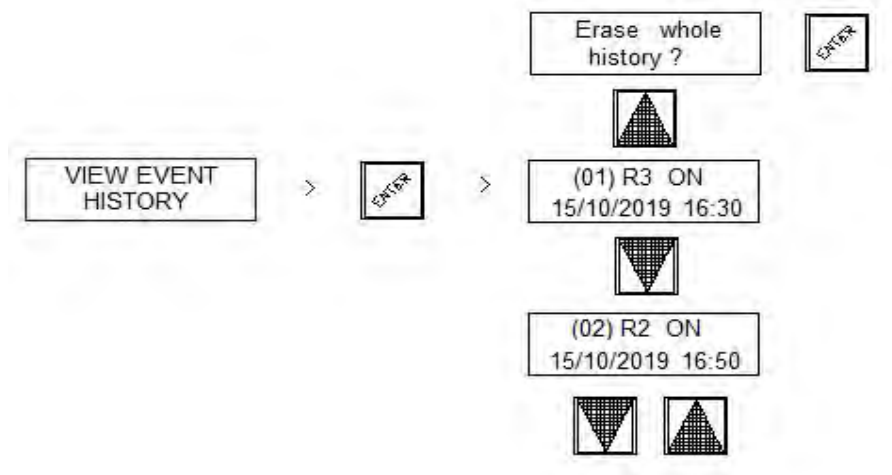

The history can be reset & cleared by pressing the **UP** button from the 1<sup>st</sup> event which prompts an "erase history message" question ..pressing **ENTER** clears the history.

## RELAY PARAMETERS PROGRAMMING

To set or edit the Relay modes of operation and switching parameters etc, Press the fascia button labeled "**ENTER**" to have the LCD display jump to the 1<sup>st</sup> menu item in the menu tree : "**SET CLOCK**", scroll down through the menu tree with the "**DOWN**" arrow button until "**RELAY PROGRAMMING**" is displayed. Press the "**ENTER**" button to open this menu. A "**summary screen**" (not editing screen) is then be displayed for Relay 1, the other 3 relay summary screens can be seen by simply scrolling up or down this sub menu using the "**UP** or **DOWN**" arrow buttons. To edit the parameters for a particular relay, whilst at its summary screen press the "**ENTER**" button to display its 1<sup>st</sup> item to edit which is "**MODE**" of operation -: the relays can be set as "**UNUSED**" , "**COOL ONLY**" (**C**), "**HEAT ONLY**" (**H**), "**HEAT & COOL**" (**B**) (which is short for acting as BOTH a heating & a cooling mirrored stage), "**CO2**" (**0**) control or as an (auxiliary) **TIME SWITCH** (**2**) relay. If a relay is not required, to save confusion, set it to "**UNUSED**" (it's associated led will also be disabled).

**RELAY SUMMARY SCREEN EXAMPLES**

- R** = RELAY # (1-4)
- M** = MODE OF OPERATION (H,C, B, 0, TIME SW2)
- D\_B** = DEADBAND (0-25c)
- S\_D** = SWITCHING DIFFERENTIAL(0.1-20c)
- Tdly** = TIME DELAY (0-99 min)

A HEATING STAGE SUMMARY SCREEN



CO2 SUMMARY SCREEN

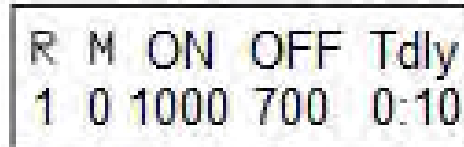

**SETTING SCREEN LABEL DESCRIPTIONS**

- MODE** : Sets what control function the relay serves : HEAT, COOL, BOTH, CO2 or as an Auxiliary Time Switch relay.
- DEADBAND** : The temperature gap in degrees C, from the controllers setpoint until the relay is enabled to turn ON.
- SW(itch) DIFF(erential)** : The amount of temperature change in degrees C back towards the setpoint to turn the stage off again.
- SW(itch ON) DELAY** : Delay in Minutes & Seconds until the relay stage turns on after exceeding the deadband setting.

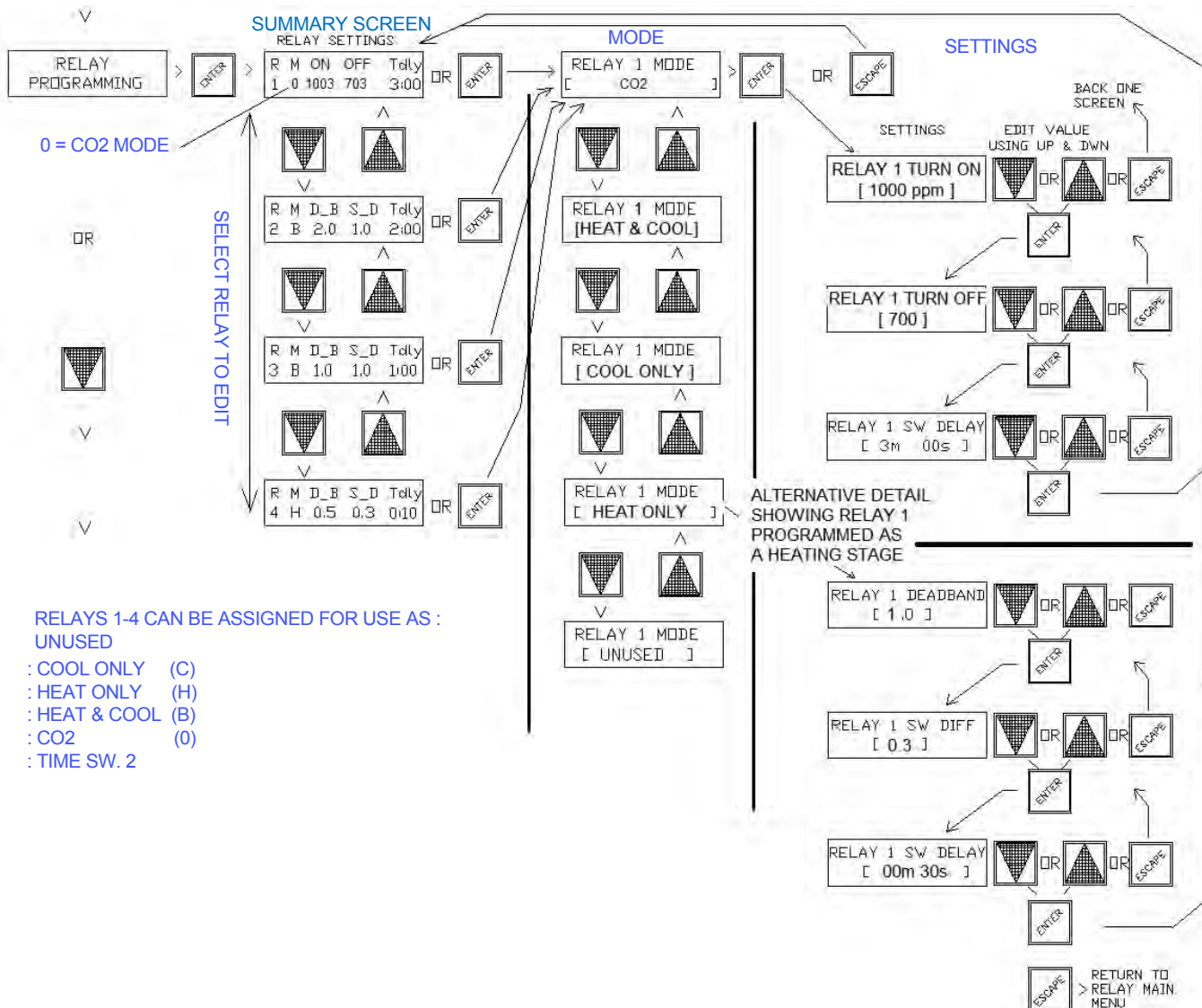

## R5 FAN CONTROL METHOD

Another update with this latest version of the ENDEAVOUR is the ability to choose, whilst this air conditioning system is enabled to run (whether that be "ON BY" : Time Switch, Run Timer or set to operate by Manual on/off switch), that the fan relay - R5, can be set to remain ON continuously (default) during the ON running period of the system or for the fan (R5) be set to cycle on & off when a relay programmed as a heating or cooling temperature control stage enables. To set the fan control method of R5, press the fascia button labeled "ENTER" and scroll down through the menu tree until "R5 FAN CONTROL METHOD" is displayed. Press the "ENTER" button to open this menu. The existing method is displayed. The fan cycle method is a typical mode of fan operation in a domestic installation to save on power & noise but in commercial buildings typically regulations call for the fan to remain on continuously whilst the building is occupied to meet minimum building ventilation requirements, if however minimum ventilation is achieved by some other means, it may be preferable to have the fan cycle with the heating or cooling as required to reduce drafts & noise when the temperature is comfortable.

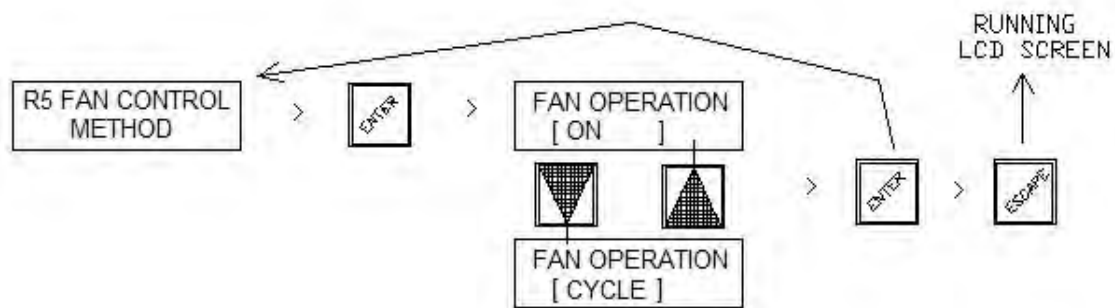

## Y1 & Y2 ANALOGUE (OUTPUTS) PROGRAMMING

To set or edit the two analogue outputs (Y1 & Y2) for mode of operation and output characteristics,

Press the fascia button labeled "ENTER" to have the LCD display jump to the 1<sup>st</sup> menu item in the menu tree.. "SET CLOCK", scroll down through the menu tree with the "DOWN" arrow button until

"Y1 & Y2 ANALOGUE PROGRAMMING" is displayed. Press the "ENTER" button to open this menu. A summary screen is then displayed for Analogue output Y1, The other analogue output Y2 summary screen can be seen by simply scrolling down this sub menu using the "DOWN" arrow button. To edit the parameters for a particular analogue output, whilst at its summary screen press the "ENTER" button to display its 1<sup>st</sup> item to edit which is "MODE" of operation -: the analogue outputs can be set as a HEATING ONLY, COOLING ONLY, "BOTH" mode output or DISABLED. Both means the analogue output will function as both a heating and a cooling output with its parameters mirrored to operate on either side of the controller's setpoint: if for example the deadband is set to 1 degree, then the analogue output will start to produce a DC output voltage from 1 degree above and 1 degree below setpoint. If an analogue output is not needed it can be set to "DISABLED". If both Y1 & Y2 are both disabled they will not appear in the scrolling running display screens. It is also now possible to set each Y outputs min & max O/P values, but note the minimum value is overridden and set to 0v when the controller is in the OFF mode.

**Y1 & Y2 ANALOGUE (OUTPUTS) PROGRAMMING...CONTINUED**

**EXAMPLE OF ANALOGUE SUMMARY SCREEN**

- Y = ANALOGUE O/P # (Y1 or Y2)
- M = MODE OF OPERATION (H,C or B)
- D\_B = DEADBAND (0-25c)
- P\_B = PROPOTIONAL BAND (1-25c)
- P+I = INTEGRAL TIME (1-60min or -P- only)

Y	M	D_B	P_B	P+I
1	C	0.0	1.0	-P-

- MODE** : Y output used as a Heating O/P, a Cooling O/P or set to act as BOTH a Heating & Cooling O/P.
- DEADBAND** : The temperature gap from the controller's setpoint till the Y produces an O/P
- PROB(portional) BAND** : The change of temperature over which the Y O/P would increase to 10volts
- INT(egral) TIME** : Time in minutes that the integral action adds the P only output to itself over the integral time setting. Note P+I action starts as the output produced by proportional only O/P exceeds 10%.

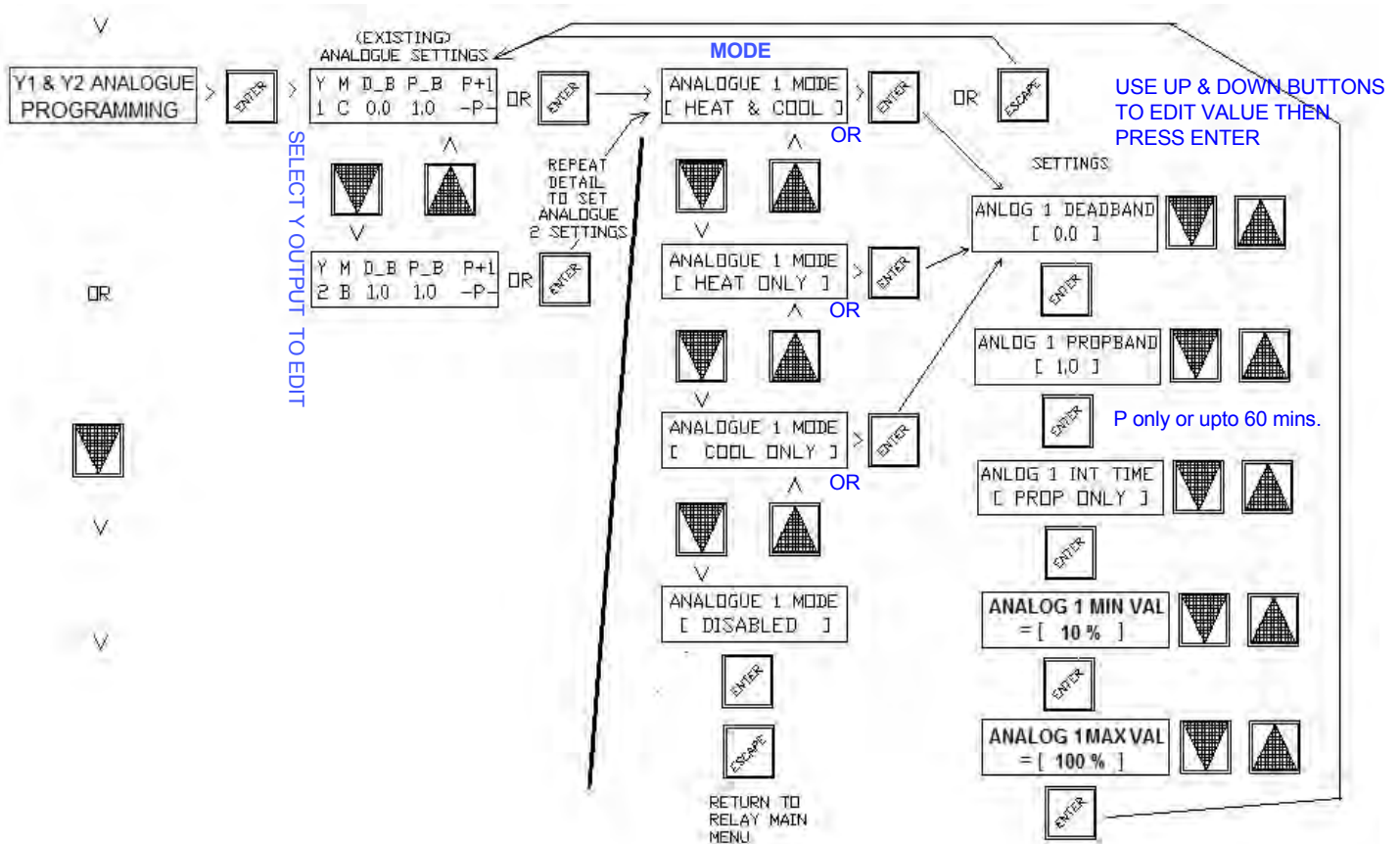

*Another possible alternative use for the Y1 & Y2 analogue outputs could be for use as an EC FAN time switch controlled run & speed setting module, the controller could be set to time switch only mode but with Y1 (as an example) set to a minimum output of 50% (which is still accessible even in time switch only mode). When the time switch 1 is ON, Y1 would produce 5v (EC fan ~ 50%) and when the time switch turns off the Y1 output would return to 0v output.*



## X1 TEMP. SENSOR CONFIGURATION (sensor type & span settings)

X1 is the main temperature sensor input that the operating setpoint relates to. The input can be set either as a Passive (Hevac type -D sensors) (default) or as an Active type (0-10vdc) in software but must also be selected as a passive or active type in hardware with a small jumper (CN1) on the bottom circuit board to match the software setting. Offset (cal) adjustment is settable for both passive & active types & for active sensors the maximum range is also adjustable ie: 10v = 20 ~ 100c

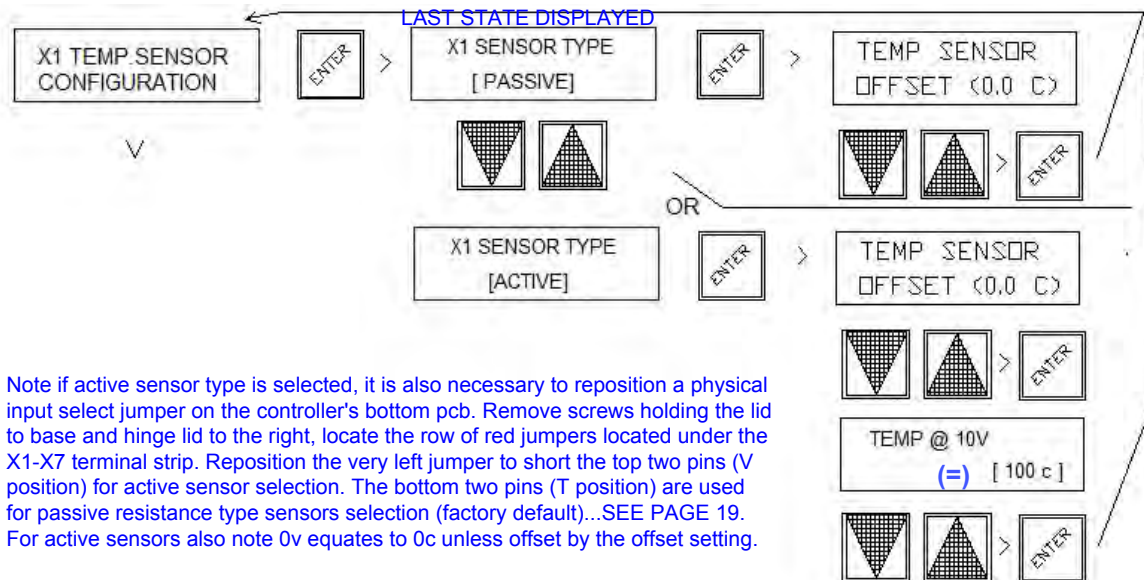

Note if active sensor type is selected, it is also necessary to reposition a physical input select jumper on the controller's bottom pcb. Remove screws holding the lid to base and hinge lid to the right, locate the row of red jumpers located under the X1-X7 terminal strip. Reposition the very left jumper to short the top two pins (V position) for active sensor selection. The bottom two pins (T position) are used for passive resistance type sensors selection (factory default)...SEE PAGE 19. For active sensors also note 0v equates to 0c unless offset by the offset setting.

## X2 REMOTE SET POINT CONFIGURATION

A Remote Set Point device (either passive or active) can be connected to the controller. If a passive adjuster is connected (default setting), the controller will automatically detect and hand over set point adjustment authority to the remote device (then ignoring the controllers UP & DOWN buttons for set point adjustment). A (passive) remote set point potentiometer can be built into a room temperature sensor - Hevac room sensor model SRT-DSP or supplied as a separate stand alone device model SPA-D. The range of the passive remote set point is fixed at 18 to 25 degrees over 0 to 10K. If an active remote set point is used the 0-10vDC signal is configurable from -5 to +5c for 0v & adjustable upto 100c for 10v.

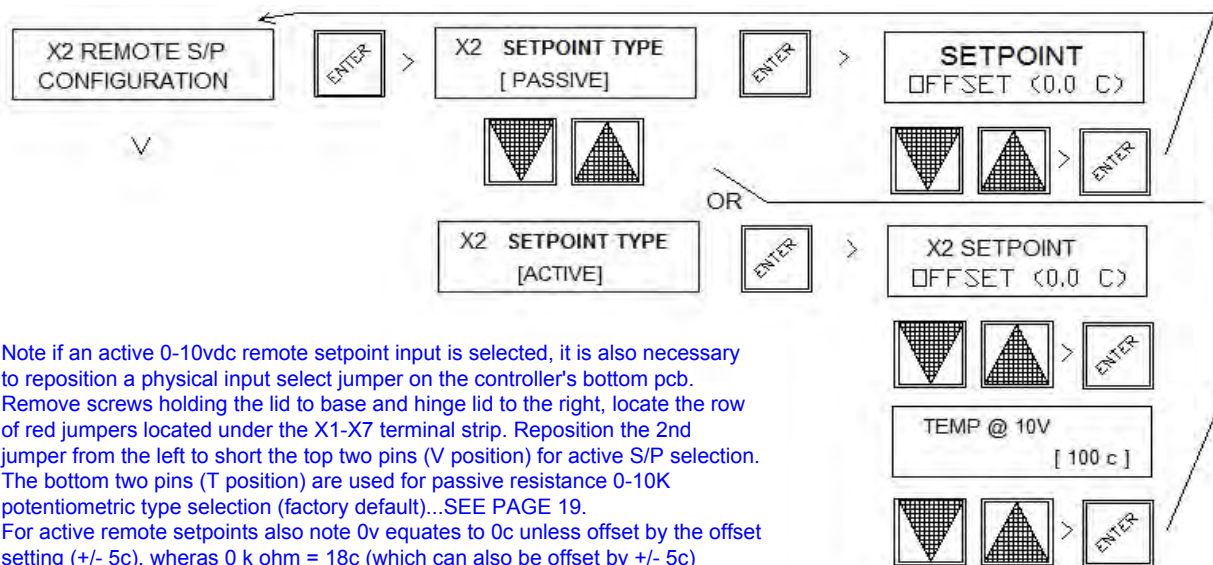

Note if an active 0-10vdc remote setpoint input is selected, it is also necessary to reposition a physical input select jumper on the controller's bottom pcb. Remove screws holding the lid to base and hinge lid to the right, locate the row of red jumpers located under the X1-X7 terminal strip. Reposition the 2nd jumper from the left to short the top two pins (V position) for active S/P selection. The bottom two pins (T position) are used for passive resistance 0-10K potentiometric type selection (factory default)...SEE PAGE 19. For active remote setpoints also note 0v equates to 0c unless offset by the offset setting (+/- 5c), whereas 0 k ohm = 18c (which can also be offset by +/- 5c)

## X3 O/AIR TEMPerature SENSOR CONFIGURATION

Economy cycle operation using analogue output Y1 can be interlocked with an outside air temperature sensor (either passive or active) connected to terminal X3, such that the use of a modulating motorised economy cycle damper set is inhibited for temperature control unless the outside air temperature is more favorable for temperature control than using recycled air from the controlled space. A low limit outside air temperature can also be set to inhibit Y1 economy cycle output if the O/A temperature is below an adjustable setting.

To enable this feature, Press the fascia button labeled “ENTER” to have the LCD display jump to the 1<sup>st</sup> item in the menu tree “SET CLOCK”, then scroll down the menu tree list with the “DOWN” arrow button until “X3 O/AIR TEMP.CONFIGURATION” is displayed. Press the “ENTER” button to open this menu and the existing status is displayed. If “DISABLED” is displayed press the “DOWN” arrow button to change the setting to ‘ENABLED” then press “ENTER”.

The following user setting can then be edited using the “UP, DOWN & ENTER buttons:

**SENSOR TYPE:** **PASSIVE:** 4K@25C 2 wire Sensor (SOT-D) or  
**ACTIVE:** 0-10V~0-100C 3 wire Sensor (OSAO)

**O/A TEMP Y1** low limit O/P lock out : < 0-20C (factory default =16c)

**ALLOW Y1 IF O/A BETTER (then room) BY :** 0.3-10C (factory default=0.5)

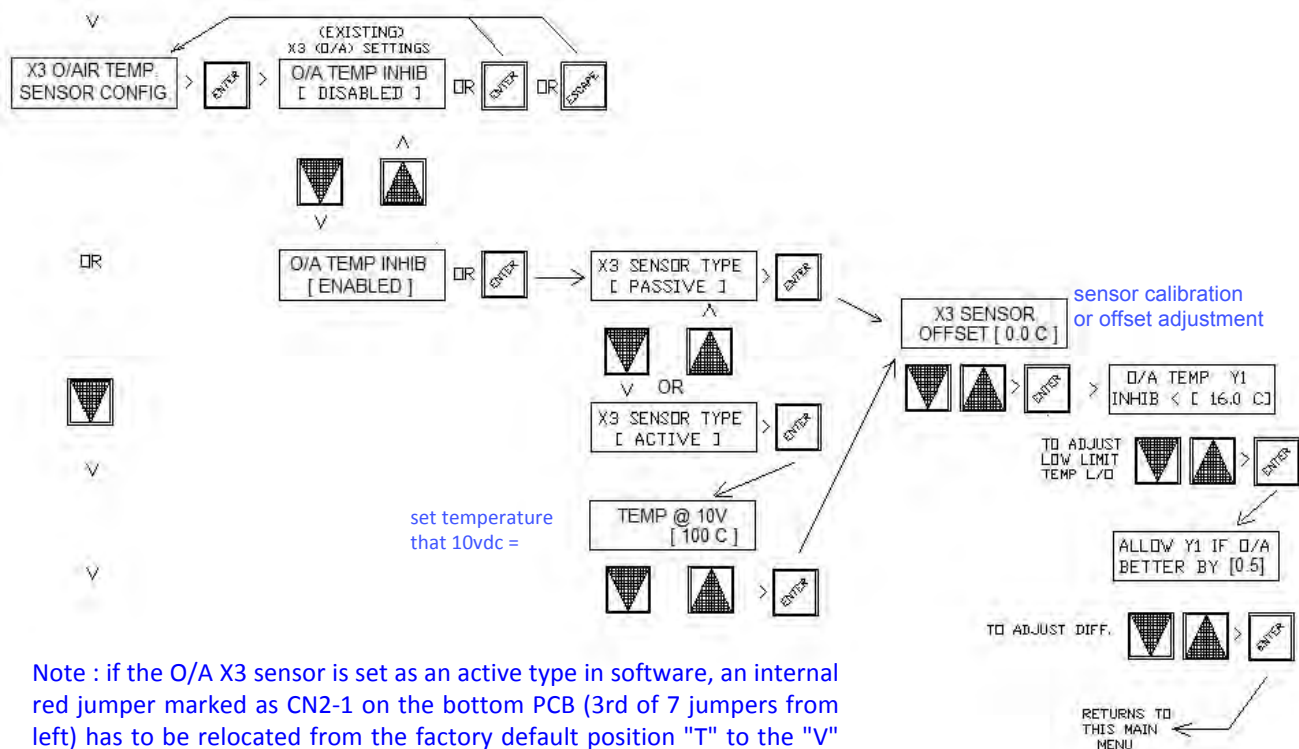

Note : if the O/A X3 sensor is set as an active type in software, an internal red jumper marked as CN2-1 on the bottom PCB (3rd of 7 jumpers from left) has to be relocated from the factory default position "T" to the "V" position.....SEE IMAGE ON PAGE 19

## CONTROLLER BOTTOM PCB SHOWING SENSOR PASSIVE / ACTIVE RED SELECTION PINS

**CN1-1 : X1 MAIN SENSOR**  
**CN1-2 : X2 REMOTE SETPOINT**

**CN2-1 : X3 O/A SENSOR**  
**CN2-2 : X4 AUX. SENSOR**

**CN3-1 : X5 MODBUS A**  
**CN3-2 : X6 MODBUS B**  
**CN3-3 : X7 CO2 SENSOR**  
**OR MODBUS SHIELD**

MOVE 1ST JUMPER TO TOP 2 PINS (V POS.) TO ALLOW USE OF ACTIVE 0-10VDC SENSOR ON X1

MOVE 2nd JUMPER TO TOP IF ACTIVE S/P 0-10v USED

MOVE 3rd JUMPER TO TOP 2 PINS IF AN ACTIVE 0-10VDC O/A SENSOR USED (X3)

MOVE 4th JUMPER TO TOP 2 PINS IF AN ACTIVE 0-10VDC Aux. SENSOR USED (x4) MOVE THESE 2 JUMPERS TO "C" POSITION TO USE MODBUS ON X5,6

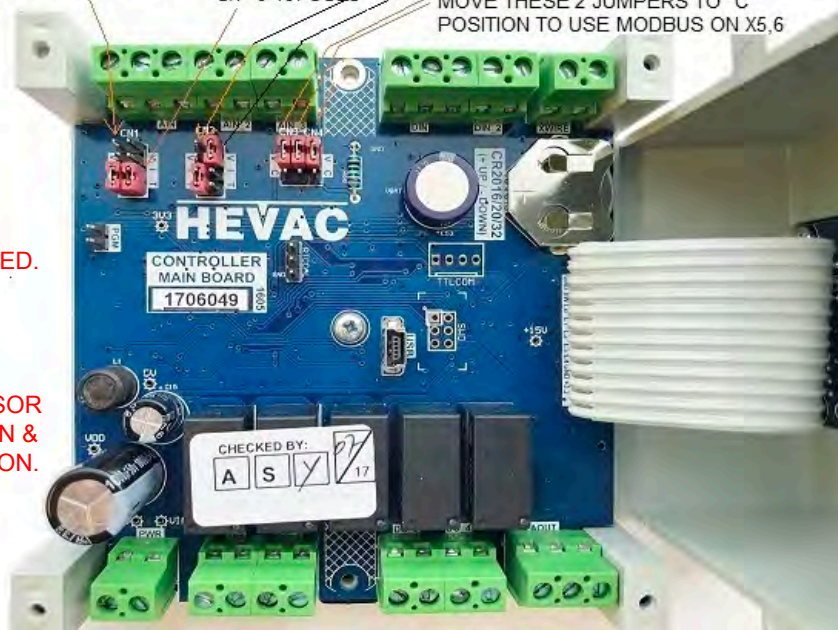

TO USE ACTIVE SENSORS INSTEAD OF PASSIVE , MOVE JUMPERS AS INDICATED.

MODBUS ( TERMINALS X5 & X6 ) ARE FACTORY SET TO COMMS MODE "C" USING THE CN3-1 & 2 JUMPERS. ALSO IF X7 ISNT BEING USED AS A CO2 SENSOR INPUT, MOVE CN3-3 TO THE C POSITION & USE X7 FOR CABLE SHIELD CONNECTION.

## X4 SUPPLY AIR TEMP. SENSOR CONFIGURATION

X4 is an auxiliary sensor input mainly intended for supply air measurement as feedback on the performance of the air conditioning supply air output, but currently performs no other function (In future updates this sensor could be used for room to supply air cascade control or supply air min / max limitation). This sensor reading is also available in the modbus output for zone display information on the Hevac HMI panel or for use by 3rd party BMS suppliers. The input can be set as either a Passive (Hevac type -D sensors) or as Active type (0-10vdc) in software but must also be selected as a passive or active type in hardware with a small jumper (CN2-2) on the bottom circuit board to match the software setting. Offset (cal) adjustment is settable for both passive & active types & for active sensors the maximum range is also adjustment ie: 10v = 20 ~ 100c

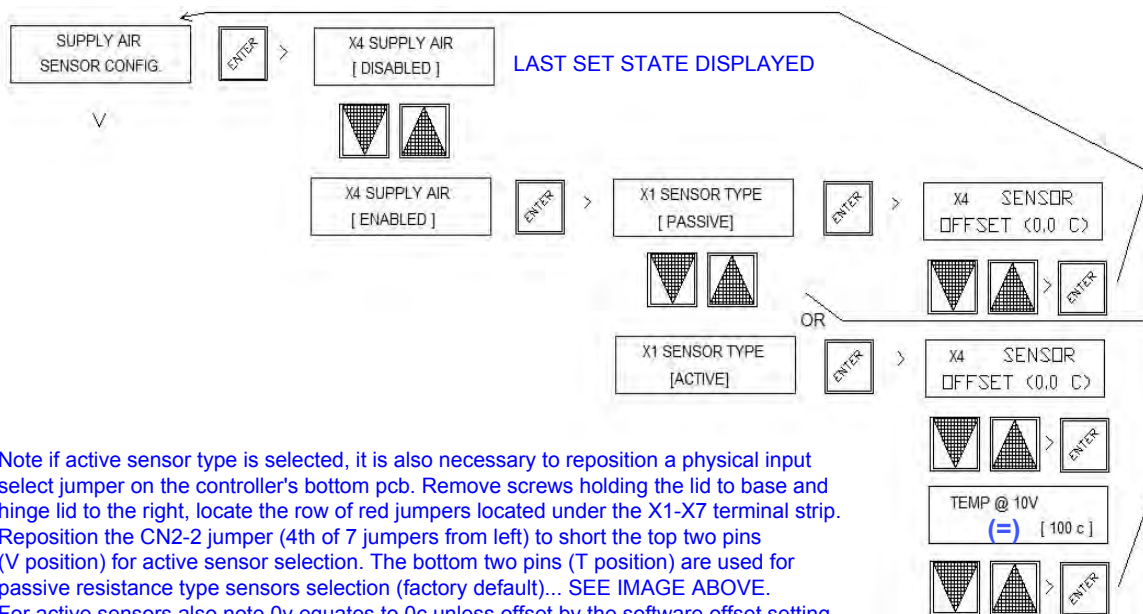

Note if active sensor type is selected, it is also necessary to reposition a physical input select jumper on the controller's bottom pcb. Remove screws holding the lid to base and hinge lid to the right, locate the row of red jumpers located under the X1-X7 terminal strip. Reposition the CN2-2 jumper (4th of 7 jumpers from left) to short the top two pins (V position) for active sensor selection. The bottom two pins (C position) are used for passive resistance type sensors selection (factory default)... SEE IMAGE ABOVE. For active sensors also note 0v equates to 0c unless offset by the software offset setting...

## X7 CO2 ECONOMY CYCLE OVERRIDE SETTINGS

Enable this feature if a CO2 sensor is connected to the controller for air quantity control to reduce CO2 build up, by either overriding the economy cycle damper operation connected to analogue output terminal Y1 (to increase fresh air intake) **or / &** to control an internal relay set for on/off CO2 control. Typical settings (factory default if enabled ) are to proportionally modulate open the economy cycle damper set to the fresh air mode as CO2 levels exceeds 700 ppm and cause full fresh air mode if levels reach 1000 ppm, or with this latest update can now alternatively just operate a relay for on/off CO2 control ..ie for energising a fresh air fan.

To edit settings, press the fascia button labeled “**ENTER**” to have the LCD display jump to the 1<sup>st</sup> menu item in the menu tree “**SET CLOCK**”, using the DOWN arrow button scroll down the menu until “**X7 CO2 SENSOR CONFIGURATION**” is displayed. To then enable this feature, Press the “**ENTER**” button followed by the “**DOWN**” arrow button to change the “**DISABLED**” setting to ‘**ENABLED**’. Either except the default settings of (Y1 damper output) start at 700 and range over 300 ppm or edit the values with the “**UP**” or “**DOWN**” buttons, press “**ENTER**” to confirm settings. Note so as not to lose temperature control in extreme outside air temperatures, O/A temperature limits can be set to inhibit full fresh mode due to high CO2 levels when the outside air temperature is either to hot or too cold (adjustable). In this menu set the high and low outside air temperatures where fresh air mode output signal (due to CO2 control) should be restricted (factory settings are: below 10c and above 35c), the now restricted CO2 generated Y1 output signal is adjustable from 0 to 100% (factory setting is 50%).

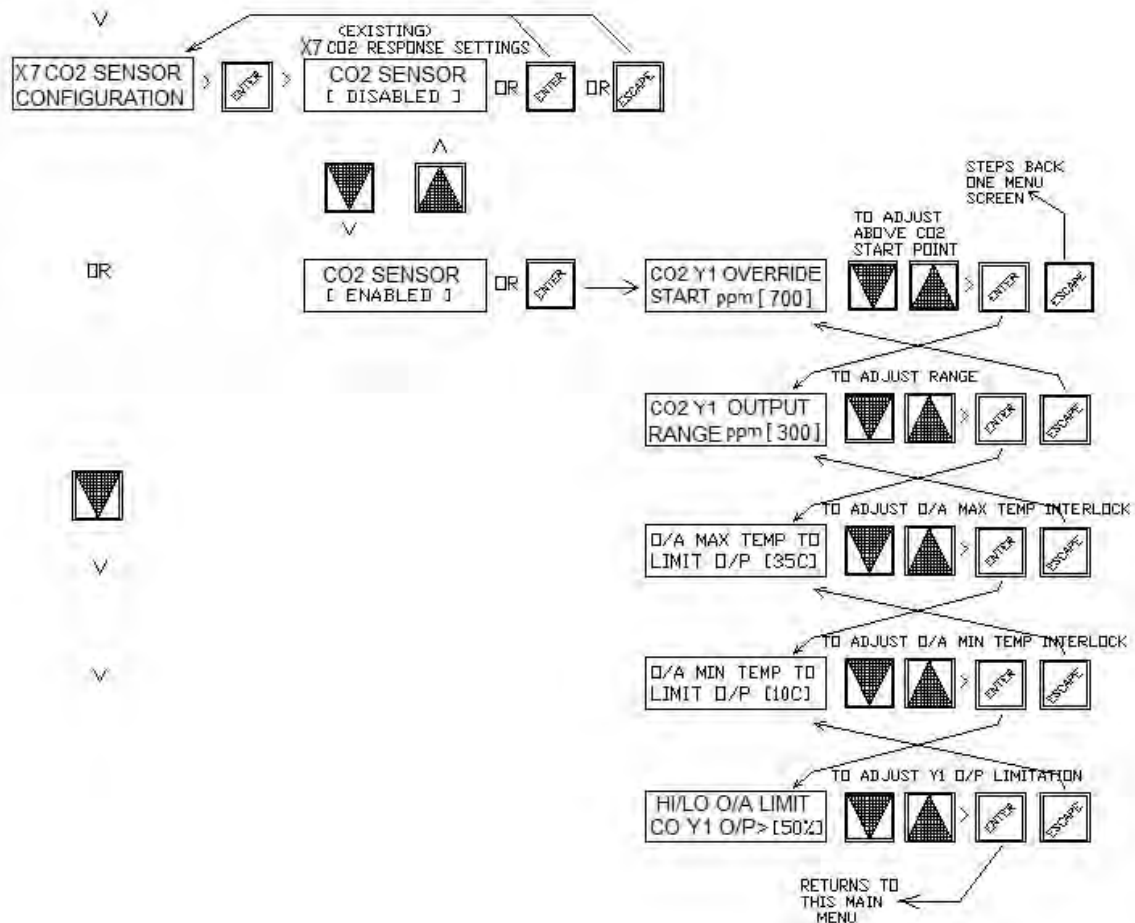

# ENABLE NIGHT PURGE

With this feature enabled it is possible to setup a low running cost building night time ventilation purge cycle, to vent built up heat from within the building with cooler outside air in order to reduce the cost of mechanical cooling during occupancy hours at startup. During the user programmable **enable times**, if the **room temperature is above the main set point** and the measured **outdoor temperature is cooler** by an adjustable amount to the room temperature, this software will cause the supply fan (connected to relay 5) to energise & the modulating motorised economy cycle dampers (connected to analog output Y1) to reposition to the full fresh air mode. These output states are maintained until the room temperature drops to a settable temperature difference in relation to the outside air temperature or / & the O/A temperature rises above the room temperature setpoint, or the enable time ends.

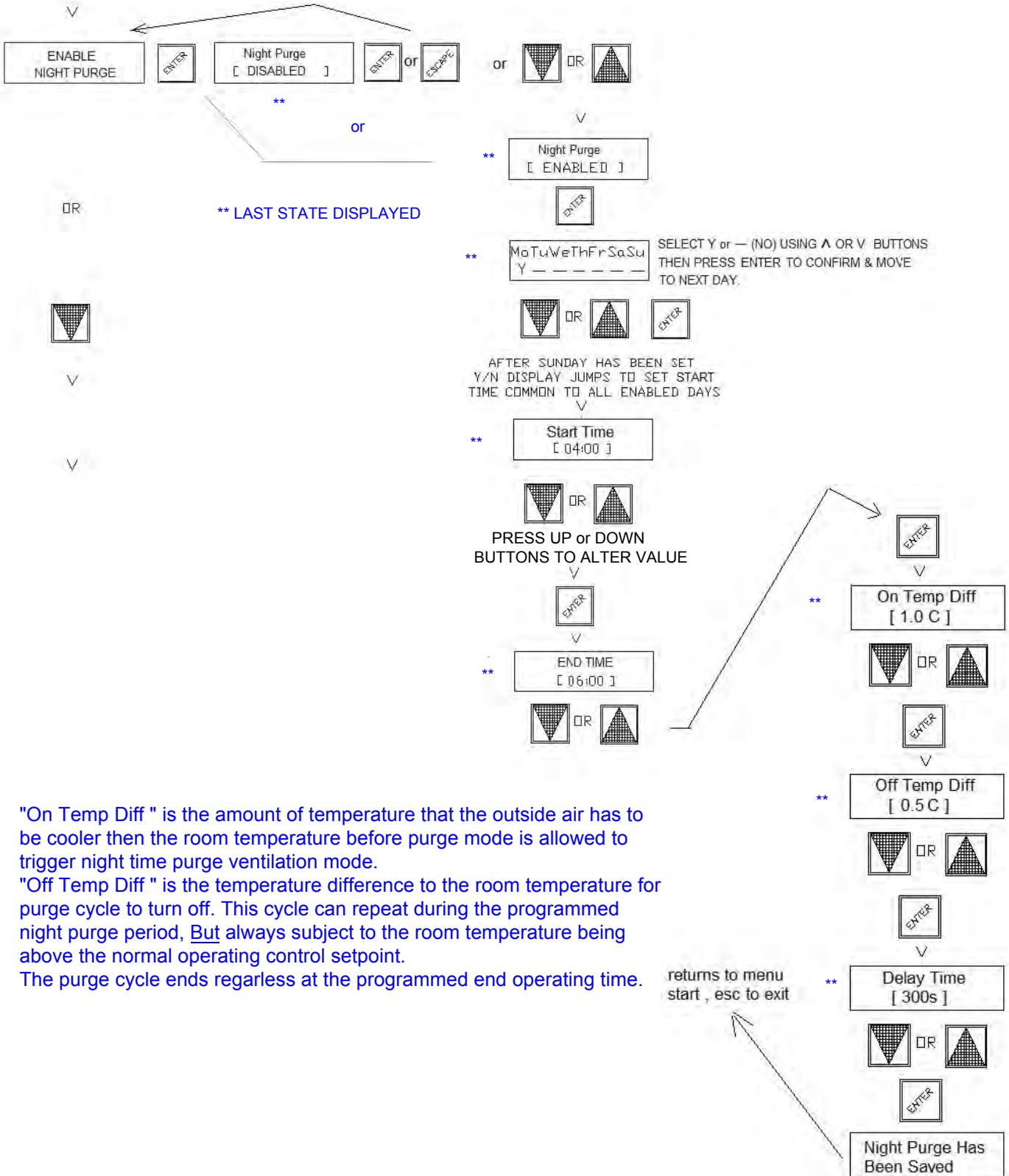

"On Temp Diff " is the amount of temperature that the outside air has to be cooler then the room temperature before purge mode is allowed to trigger night time purge ventilation mode.

"Off Temp Diff " is the temperature difference to the room temperature for purge cycle to turn off. This cycle can repeat during the programmed night purge period, But always subject to the room temperature being above the normal operating control setpoint.

The purge cycle ends regardless at the programmed end operating time.

returns to menu start , esc to exit

# MODBUS SETUP & MEMORY MAP

Modbus connections X5 (A) & X6 (B) are factory enabled by default using the bottom circuit board input pins CN3-1&2.

NOTE If X7 isnt used for CO2 measurement , X7 can be set as ground source for the modbus shield connection by setting input pin CN4 to the "C" position, otherwise the shield wire needs to be connected to a good earth. CN4 by default is set to the "V" position for X7 to be used as a CO2 input.

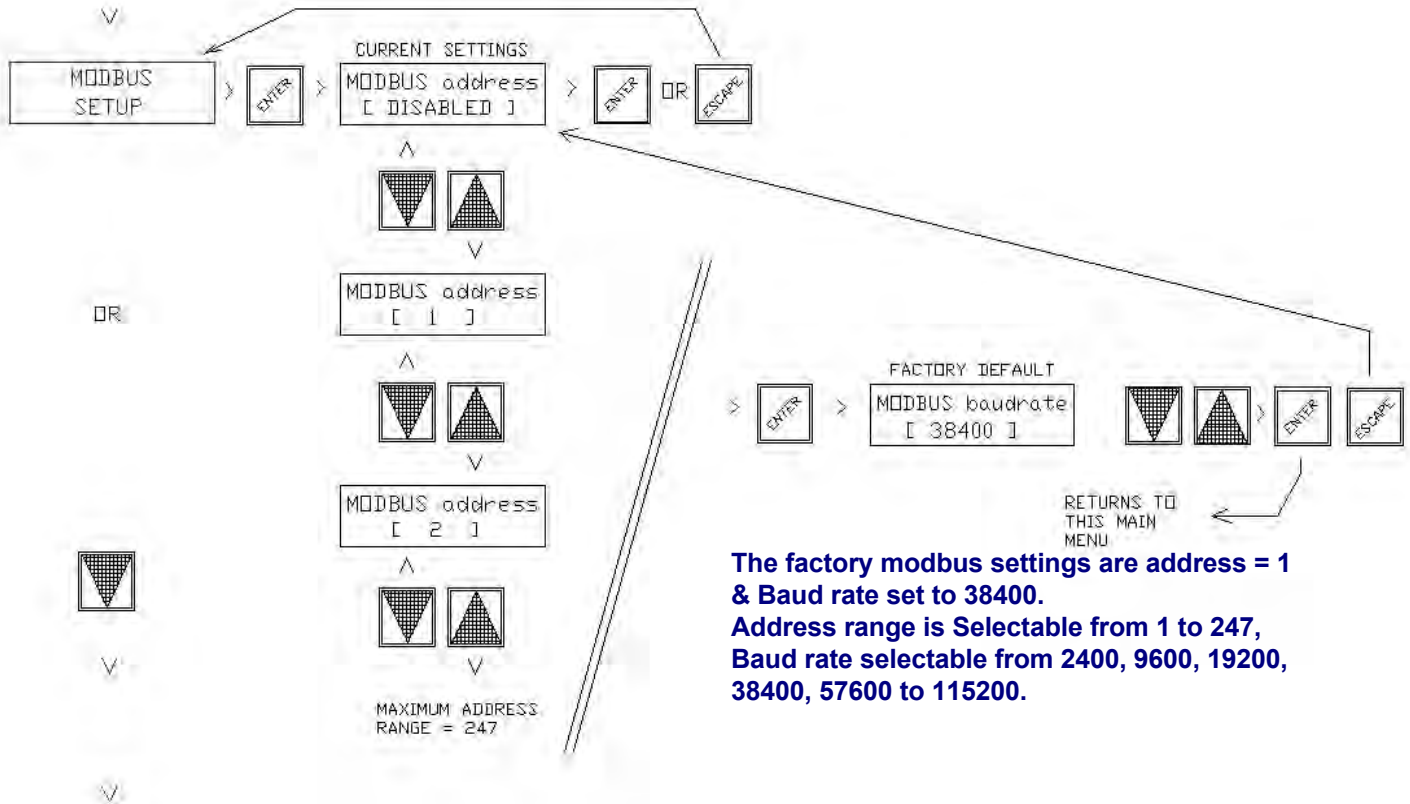

Hevac Temperature Controller							Defau	Error	Intern	Intern
Modic	Address	Access	Description	Units	Type	Explanation			Address	Byte
on	s								Address	Address
<b>Read Coils</b>										
00161	160	ReadOnly	Running	-	boolean	TRUE if the unit is running, FALSE if not	-	-	00160	20.0
00162	161	ReadOnly	Outdoor Temp Sensor Present	-	boolean	TRUE if the outdoor temperature sensor is fitted, FALSE if not	-	-	00161	20.1
00163	162	ReadOnly	CO2 Sensor Present	-	boolean	TRUE if the CO2 sensor is fitted, FALSE if not	-	-	00162	20.2
00164	163	ReadOnly	Night Purge Active	-	boolean	TRUE if Night Purge is active	-	-	00163	20.3
00165	164	ReadOnly	Off by external switch	-	boolean	TRUE if external switch is active	-	-	00164	20.4
00166	165	ReadOnly	Supply Air Fitted	-	boolean	TRUE if the Supply Air Duct temperature sensor is in use	-	-	00165	20.5
01001	1000	ReadOnly	Relay 1	-	boolean	TRUE if relay is active	-	-	00000	n/a
01002	1001	ReadOnly	Relay 2	-	boolean	TRUE if relay is active	-	-	00001	n/a
01003	1002	ReadOnly	Relay 3	-	boolean	TRUE if relay is active	-	-	00002	n/a
01004	1003	ReadOnly	Relay 4	-	boolean	TRUE if relay is active	-	-	00003	n/a
01005	1004	ReadOnly	Relay 5 (Fan)	-	boolean	TRUE if relay is active	-	-	00004	n/a
<b>Inputs</b>										
10001	0	ReadOnly	input 0 (D1)	-	boolean	Manual System OFF (longer then 3 secs) & AHR input (momentary). TRUE if input is on, FALSE otherwise	-	-		
10002	1	ReadOnly	input 1 (D2)	-	boolean	Manual 24/7 System ON override. TRUE if input is on, FALSE otherwise	-	-		
10003	2	ReadOnly	input 2 (D3)	-	boolean	A/C FAULT input. TRUE if input is on, FALSE otherwise	-	-		
10004	3	ReadOnly	input 3 (D4)	-	boolean	Auxiliary input for general use by 3rd party BMS input monitoring. TRUE if input is on, FALSE otherwise	-	-		
<b>Write Coils</b>										
00169	168	Read/write	MODBUS Master write Requ	-	boolean	TRUE if a master is connected, <b>only required if MB Master is writing</b> . Sampled every 60 seconds. modbus write Pegs will be cleared if not set and the controller will return to local values.	-	-	00168	210
<b>Read Registers</b>										
45001	5000	ReadOnly	Controller model	-	unsigned 16bit	Controller model number	1	-		
45002	5001	ReadOnly	MODBUS mapping version	-	unsigned 16bit	MODBUS memory/coil mapping version number	1	-		
41171	1171	ReadOnly	Relay 1 use Mode	Byte	unsigned 8bit	Relay mode settings: 0=unused, 1=Cool, 2=Heat, 3=Heat&Cool, 4=CO2, 5= Time Switch 2	0	-		171
41172	1172	ReadOnly	Relay 2 use Mode	Byte	unsigned 8bit	Relay mode settings: 0=unused, 1=Cool, 2=Heat, 3=Heat&Cool, 4=CO2, 5= Time Switch 2	0	-		172
41173	1173	ReadOnly	Relay 3 use Mode	Byte	unsigned 8bit	Relay mode settings: 0=unused, 1=Cool, 2=Heat, 3=Heat&Cool, 4=CO2, 5= Time Switch 2	0	-		173
41174	1174	ReadOnly	Relay 4 use Mode	Byte	unsigned 8bit	Relay mode settings: 0=unused, 1=Cool, 2=Heat, 3=Heat&Cool, 4=CO2, 5= Time Switch 2	0	-		174
43014	3013	ReadOnly	(X2 or internal) Setpoint	celcius * 10	signed 16bit	Setpoint temperature. To display in celsius, divide by 10 and display with one decimal place.	-	-		26 - 27
43015	3014	ReadOnly	(X1) Indoor temperature	celcius * 10	signed 16bit	Indoor temperature. To display in celsius, divide by 10 and display with one decimal place.	-	9999		28 - 29
43016	3015	ReadOnly	(X3) Outdoor temperature	celcius * 10	signed 16bit	Outdoor temperature. To display in celsius, divide by 10 and display with one decimal place.	-	9999		30 - 31
43017	3016	ReadOnly	(X7) CO2	ppm	signed 16bit	CO2 level in ppm.	-	-		32 - 33
43018	3017	ReadOnly	Y1 0-10vdc Analogue Output	percent * 10	signed 16bit	Percent drive level, eg 513 = 51.3%	-	-		34 - 35
43019	3018	ReadOnly	Y2 0-10vdc Analogue Output	percent * 10	signed 16bit	Percent drive level, eg 513 = 51.3%	-	-		36 - 37
43020	3019	ReadOnly	(X4) Supply Air temperature	celcius * 10	signed 16bit	Supply Air Duct temperature. To display in celsius, divide by 10 and display with one decimal place.	-	9999		38 - 39
<b>Write Registers</b>										
41023	1022	Read/write	System Enable Operating mo-	-	unsigned 16bit	Operating mode: 0 = auto, 1 = force on, 2 = force off	0	-		22
43013	3012	Read/write	MODBUS setpoint	celcius * 10	unsigned 16bit	MODBUS controller setpoint, temperature = MODBUSSetpoint/10. 0 means use local setpoint	0	-		24 - 25

# SET CONTROL APPLICATION

The Endeavour controller can now be set to operate in a time switch only mode inhibiting most other control functions other than time switches & timers. Functions enabled : Time Switch 1, Time Switch 2 , Run Timer & AUTO /OFF / ON system overrides modes. Under this menu select "STANDARD TEMP. APPLICATION" or "TIME SWITCH ONLY" mode.

NOTE : Y1 & Y2 can still be set to a minimum value even in time switch only mode for use as a time switch controlled fixed analogue output module.

**\*\* CYCLE POWER OFF & ON TO LOAD & TRIGGER THIS NEW APPLICATION\*\***

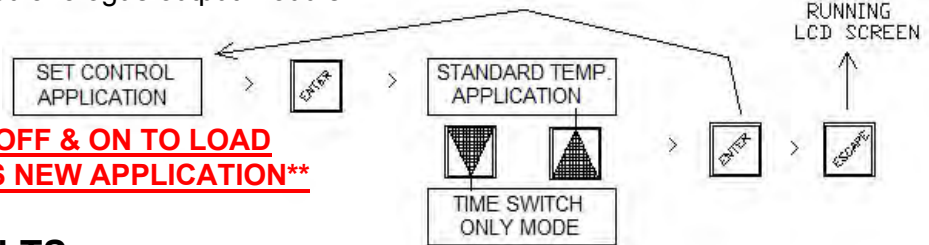

## FACTORY DEFAULTS

"START BY" MODE SET TO TIME SWITCH, MONDAY -FRIDAY 08:00 - 17:30

RELAYS SET FOR 3 STAGE REVERSE CYCLE A/C UNIT CONTROL

Y1 SET AS ECONOMY CYCLE O/P (cool only) in P only mode. (F/A sensor interlock not enabled)

Y2 SET AS MODULATING COMPRESSOR 1 OUTPUT (P only mode)

AHR TIMER SET FOR 2 HOURS

RELAY	MODE	DB	SD	PB	I	TD	USE
R1	B	3.0	1.0			3.0	HEAT & COOL STAGE 3 (COMP.3)
R2	B	2.0	0.7			2.0	HEAT & COOL STAGE 2 (COMP.2)
R3	B	1.0	0.3			1.0	HEAT & COOL STAGE 1 (COMP.1)
R4	H	0.5	0.4			0.1	REVERSING VALVE HEAT MODE
R5							FIXED AS SYSTEM ON RELAY (FAN)
Y1	C	0.1		1.0	P Only		ECONOMY CYCLE DAMPER O/P
Y2	B	1.0		1.0	P Only		MODULATING COMPRESSOR O/P

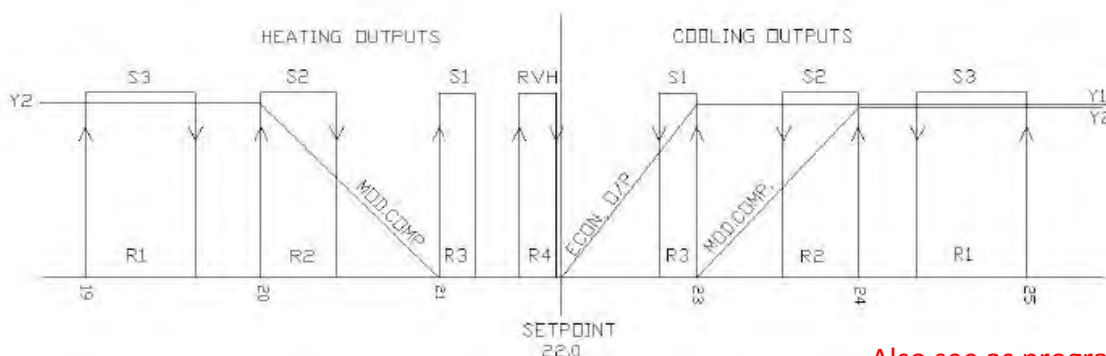

## OTHER NOTABLE FACTORY (SOFTWARE) DEFAULT SETTINGS

CONTROLLER SET AS STANDARD (TEMP.) MODE CONTROLLER

X3 (O/A), 4 (S/A) & 7 (CO2) DISABLED

X1, 2, 3 & 4 SET AS PASSIVE RESISTANCE INPUTS

X5 & 6 (MODBUS ) SOFTWARE DISABLED

TIME SWITCH 2 DISABLED

HOLIDAY DATES EMPTY

DAY LIGHT SAVINGS AUTO TIME CORRECTION DISABLED

RELAY 5 (FAN CONTROL) SET TO ON (NOT CYCLE)

NIGHT PURGE MODE DISABLED

Y1 SET AS COOL & Y2 AS BOTH, & SET FOR FULL 0-10v RANGE

X3 (O/A) IF USED, LOW LIMIT L/O = 16 & MUST BE

0.5c < X1 TEMP. FOR Y1 TEMP. ENABLE

Also see as programmed table on page 25

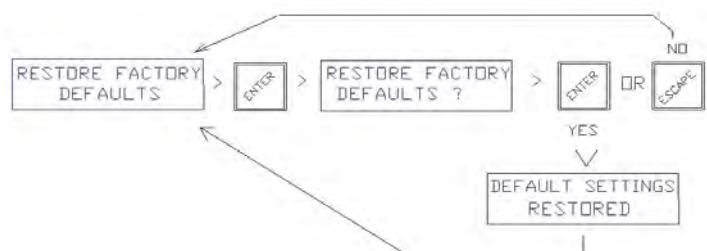

# Typical Wiring Connections

## AVAILABLE SENSORS

SRT-D	ROOM TEMPERATURE SENSOR	2 WIRE
SRT-DSW	" + ON/OFF SWITCH	2 WIRE
SRT-DSP	" C/W SETPOINT POT.	3 WIRE
SRT-DSPSW	" C/W S/P + ON/OFF SW.	3 WIRE
SDT-D	DUCT TEMPERATURE SENSOR	2 WIRE
SOT-D	OUTSIDE AIR SENSOR (PASSIVE)	2 WIRE
OSAO	OUTSIDE AIR SENSOR (ACTIVE)	3 WIRE
HCRW5	ROOM CO2 SENSOR	3 WIRE
HCRW5	ROOM TEMP. & CO2 SENSOR	4 WIRE

## OPERATIONAL NOTES:

If a **remote setpoint** device is connected (X2) then local setpoint control (via Controllers UP & DOWN buttons) is disabled.

**System Off & AHR** switch functions can be triggered by ground connections to either X1 or D1. **Manual Off** (X1 or D1) takes priority over manual On (D2).

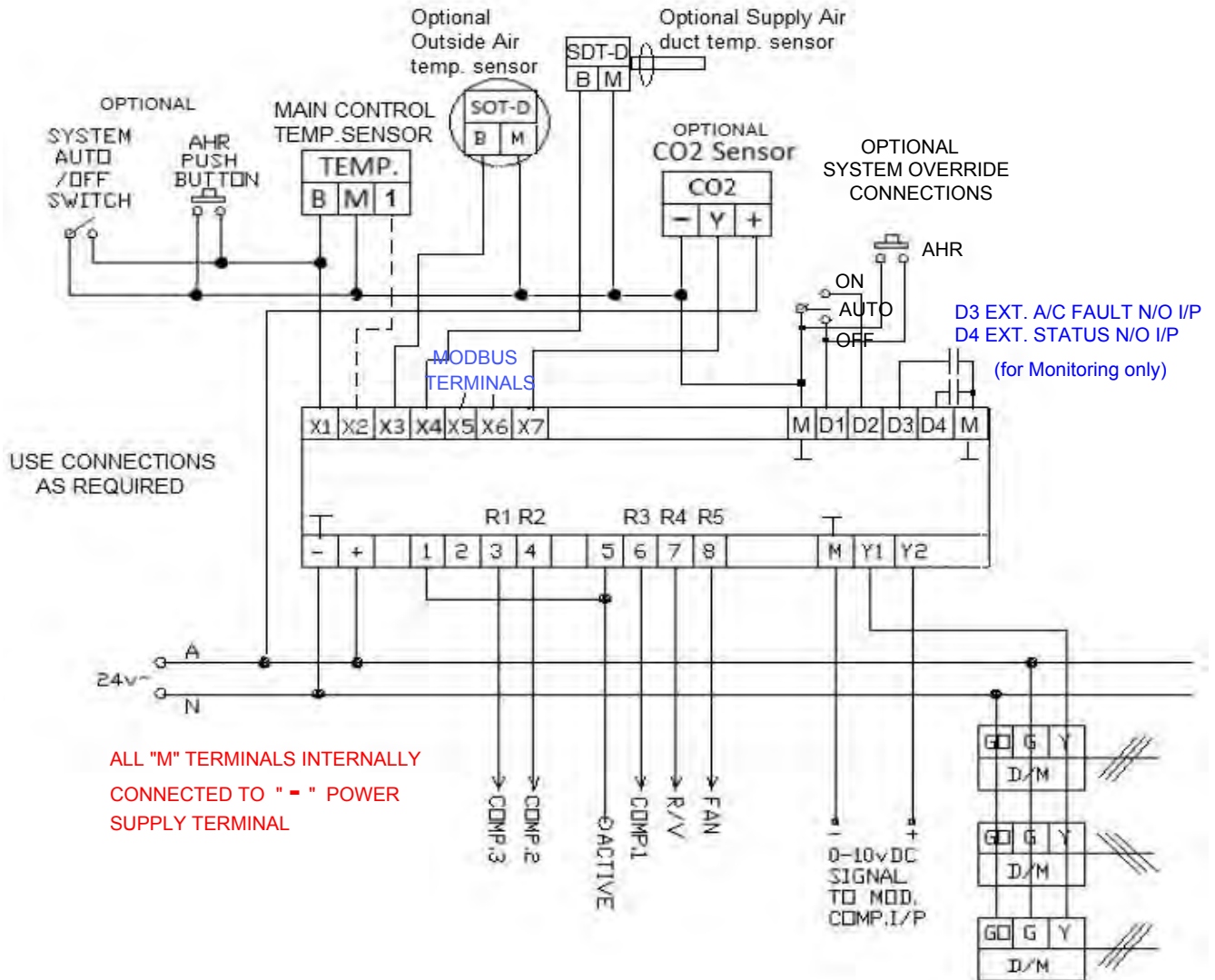

## Wiring Considerations

Supply Voltage	The Controller requires either a 12-24Volt AC or DC Supply. This diagram assumes a 24 Volt AC connection. Note terminals "M" & "-" are <b>internally</b> connected so as to allow a common ground reference.
Cabling Requirements	Its is recommended to connect remote input devices using twisted pair screened cable. Screened cable shield should be grounded to a good Earth at the controller end only.



# FACTORY SET ENDEAVOUR SITE PROGRAM INFORMATION

CONTROLLER SET TO "RUN BY" : TIME SWITCH

DAYLIGHT SAVING = **ENABLED** or DISABLED

RUN TIMER SETTING = **2 HOURS**

		M	T	W	T	F	S	S	YES(Y) or NO(-)
<b>TIME SWITCH 1</b>	EVENT 01, DAYS :	Y	Y	Y	Y	Y	-	-	TIME: <b>8:00</b> , ACTION: <b>ON</b>
"	EVENT 02 "	Y	Y	Y	Y	Y	-	-	TIME: <b>17:30</b> , ACTION: <b>OFF</b>
"	EVENT 03 "								TIME: _____, ACTION: <b>ON OFF</b>
"	EVENT 04 "								TIME: _____, ACTION: <b>ON OFF</b>
"	EVENT 05 "								TIME: _____, ACTION: <b>ON OFF</b>
"	EVENT 06 "								TIME: _____, ACTION: <b>ON OFF</b>
"	EVENT 07 "								TIME: _____, ACTION: <b>ON OFF</b>
"	EVENT 08 "								TIME: _____, ACTION: <b>ON OFF</b>

**TIME SWITCH 2**      **TIME SWITCH 2 NOT USED**      **HOLIDAYS**      **NO HOLIDAYS LOADED**

## RELAY 1 – 4 RELAY ASSIGNMENTS

RELAY I	MODE	DEADBAND(DB)	SWITCH. DIFF.(SD)	TIME DELAY (Tdly)	NOTES
1	<b>BOTH</b>	<b>3.0</b>	<b>1.0</b>	<b>3:00</b>	<b>COMPRESSOR 3</b>
2	<b>BOTH</b>	<b>2.0</b>	<b>0.5</b>	<b>2:00</b>	<b>COMPRESSOR 2</b>
3	<b>BOTH</b>	<b>1.0</b>	<b>0.3</b>	<b>1:00</b>	<b>COMPRESSOR 1</b>
4	<b>HEAT</b>	<b>0.5</b>	<b>0.4</b>	<b>0:10s</b>	<b>rev. valve HEAT</b>
5	= FAN CONTROL METHOD: <b>ON</b> or <b>CYCLE</b> (runs continuously during time switch on period.)				

## Y1 & Y2 ANALOGUE OUTPUT ASSIGNMENTS

ANALOG O/P I	MODE	DEADBAND(DB)	PROP.BAND (PB)	INTEGRAL TIME	MIN O/P	MAX O/P	NOTES
Y1	<b>COOL</b>	<b>0.0</b>	<b>1.0</b>	<b>P ONLY</b>	<b>0 %</b>	<b>100%</b>	<b>ECON.CYCLE</b>
Y2	<b>BOTH</b>	<b>1.0</b>	<b>1.0</b>	<b>P ONLY</b>	<b>0 %</b>	<b>100%</b>	<b>MOD.COMP.</b>

## "X" ANALOGUE INPUT CONFIGURATIONS

X I/P	PURPOSE	Active/Passive	OFFSET	10v=	PCB JUMPER POS.	NOTES
X1	MAIN TEMP. SENSOR	<b>PASSIVE</b>	<b>0</b>	<b>n/a</b>	<b>T</b>	<b>Main Temp Sensor</b>
X2	REMOTE SETPOINT	<b>PASSIVE</b>	<b>0</b>	<b>n/a</b>	<b>T</b>	<b>Optional remote S/P</b>
X3	OUTSIDE AIR TEMP.SENSOR	<b>PASSIVE</b>	<b>DISABLED</b>		<b>T</b>	<b>Otional O/A sensor</b>
X4	SUPPLY AIR TEMP.SENSOR	<b>PASSIVE</b>	<b>DISABLED</b>		<b>T</b>	<b>Otional S/A sensor</b>
X5	MODBUS "A" COMMUNICATION TERMINAL		<b>DISABLED</b>		<b>C</b>	
X6	MODBUS "B" COMMUNICATION TERMINAL				<b>C</b>	<b>Optional CO2 sensor</b>
X7	CO2 SENSOR		<b>DISABLED</b>		<b>V</b>	<b>sensor</b>

## OTHER SETTINGS

MODBUS = software **DISABLED**      NIGHT PURGE= **DISABLED**  
 MAIN APPLICATION PURPOSE = **STANDARD TEMP. APP**



## RELAY 1 – 4 RELAY ASSIGNMENTS

RELAY	MODE	DEADBAND(DB)	SWITCH. DIFF.(SD)	TIME DELAY (Tdly)	NOTES
1					
2					
3					
4					

**RELAY 5 FAN CONTROL METHOD:** **ON** or **CYCLE**

## Y1 & Y2 ANALOGUE OUTPUT ASSIGNMENTS

ANALOG O/P	MODE	DEADBAND(DB)	PROP.BAND (PB)	INTEGRAL TIME	MIN O/P	MAX O/P	NOTES
Y1							
Y2							

## “X” ANALOGUE INPUT CONFIGURATIONS

X I/P	PURPOSE	Active/Passive	OFFSET	10v=	PCB JUMPER POS.	NOTES
X1	MAIN TEMP. SENSOR					
X2	REMOTE SETPOINT					
X3	OUTSIDE AIR TEMP.SENSOR					
X4	SUPPLY AIR TEMP.SENSOR					
X5	MODBUS “A” COMMUNICATION TERMINAL				C	
X6	MODBUS “B” COMMUNICATION TERMINAL				C	
X7	CO2 SENSOR				V	

## OTHER SETTINGS

M, T, W, T, F, S, S

**NIGHT PURGE**= ENABLED/DISABLED, DAYS: | | | | | | | |, START TIME= : , END TIME= :  
ON DIFF = , OFF DIFF = , ON DELAY =

**MODBUS** = DISABLED / ADDRESS= , BAUDRATE =

**MAIN APPLICATION PURPOSE** = STANDARD TEMP. APP or TIME SWITCH ONLY APP.