

SDC-C1 Duct CO₂ transmitter

Features

- CO₂ measurement for air ducts
- Indication with three color led
- Minimum and maximum value memory
- 0...10 V, 0...20 mA or 2...10 V, 4...20 mA measuring signals selectable with jumpers
- Optional alternative signal ranges programmable
- May be used as simple P-controller
- Selectable averaging signal
- Optional internal or external display (OPC-S or OPA-S)
- Status LED



Applications

- Demand based ventilation for homes and offices based on measurement of the CO₂ concentration. Preset standard measuring range 0...2000 ppm, max possible range 0...5000 ppm.
- Recording of minimum and maximum limits for critical environments
- Direct control of extraction fan.

CO₂ transmitter

The CO₂ concentration is measured through non-dispersive infrared (NDIR) waveguide technology with ABC automatic background calibration algorithm. The applied measuring technology guarantees excellent reliability and long term stability. The microprocessor samples the CO₂ once per second. It calculates an averaging signal over a preset number of seconds and generates the output signal.

The output signal range and type may be customized by jumpers and if required by a programming tool. Standard signal ranges are 0...10 VDC, 2...10 VDC, 4...20 mA and 0...20 mA. These ranges can be set by jumpers. Other ranges can be set by using the internal or external display and programming module. (OPC-S or OPA-S)

Automatic baseline calibration ABC

The ABC background calibration constantly supervises the measured CO₂ concentrations. The calibration function expects the CO₂ values sink to 400 ppm when the room is not occupied. Over a period of several days the controller tries to reach this value step by step through recalibration of 30 ppm per day max. In order to reach the given accuracy, it is required that the Sensor is for at least 3 weeks in operation.

Note: The ABC calibration works only in those applications where the CO₂ concentration sinks regularly to fresh air levels of 400 ppm. For special applications such as green houses, animal farms, etc. the ABC calibration should be deactivated and the sensor should be manually calibrated. The automatic calibration can be deactivated through the external operation terminal. The Sensor can be calibrated by the client and does not need to be sent in for calibration. See last page for details.

Minimum and maximum values:

Using a display & programming accessory, the user has the option to read out and reset minimum and maximum values. The minimum and maximum values may as well be used as output signals. The minimum and maximum values are saved into the EEPROM and are available after a power interruption.

Indication of air quality indication:

A three color LED is used to indicate air quality: Green light for low CO₂ concentration, orange light for medium and red light for high concentration. The levels for low-medium-high may be programmed. Default settings are 0 ppm < low < 800 ppm < medium < 1500 ppm high.

Ordering

Item name	Item code	Description/Option
SDC-C1	40-30 0093	CO ₂ transmitter for air ducts
SDC-C1-1	40-30 0152	CO ₂ transmitter for air ducts with cable gland PG9 for cables Ø 4...8 mm (AWG 6...1) included
SDC-C1-OP	40-30 0094	CO ₂ transmitter for air ducts with integrated display
SRC-C1	40-30 0062	CO ₂ transmitter for indoor surface mounting

Accessories

Item name	Item code	Description/Option
OPC-S	40-50 0029	Built in display module
OPA-S	40-50 0006	External display module

Technical specification

Power supply	Operating voltage	24 VAC 50/60 Hz ± 10%, 24 VDC ± 10% SELV to HD 384, Class II transformer, 48 VA max	
	Power consumption	Max 2 VA	
Connection	Terminal connectors	For wire 0.34...2.5 mm ² (AWG 22...13)	
CO ₂ measurement	Sensing method	Non-dispersive infrared (NDIR) waveguide technology with ABC automatic background calibration algorithm	
	Sampling method	Diffusion	
	Response time (T _{1/e})	20 s diffusion time	
	Measurement range	0 - 5000 ppm _{vol}	
	Repeatability	± 20 ppm ± 1 % of measured value	
	Accuracy	± 30 ppm ± 3 % of measured value	
	Pressure dependence	+ 1.6% reading per kPa deviation from normal pressure, 100 kPa	
Signal outputs	Analog outputs		
	Output signal	DC 0...10 V or 0...20 mA	
	Resolution	10 Bit, 9.7 mV, 0.019.5 mA	
	Maximum load	20 mA, 500 Ω	
Environment	Operation	To IEC 721-3-3	
	Climatic conditions	class 3K5	
	Temperature	0...50 °C (32...122 °F)	
	Humidity	< 95% RH non-condensing	
	Transport & storage	To IEC 721-3-2 and IEC 721-3-1	
	Climatic conditions	class 3K3 and class 1K3	
	Temperature	-30...70 °C (-22...158 °F)	
	Humidity	< 95% RH non-condensing	
	Mechanical conditions	class 2M2	
Standards	conformity	EMC Directive	2004/108/EC
		Low voltage directive	2006/95/EC
	Product standards		
	Automatic electrical controls for household and similar use		EN 60730-1
	Special requirement on temperature dependent controls		EN 60730-2-9
	Electromagnetic compatibility for industrial and domestic sector	Emissions: EN 60730-1	Immunity: EN 60730-1
	Degree of protection to EN 60529		IP40
	Safety class		III (IEC 60536)
	Housing materials	Housing materials	PC+ABS (UL94 class V-0)
	General	Dimensions (H x W x D): Transmitter:	68 x 91 x 47mm (2.7" x 3.7" x 1.9")
Probe:		∅ 14 x 157 mm (∅ 0.55 x 6.2")	
	Weight (incl. package)	260g (9.2 oz)	

Dimensions mm (inch)

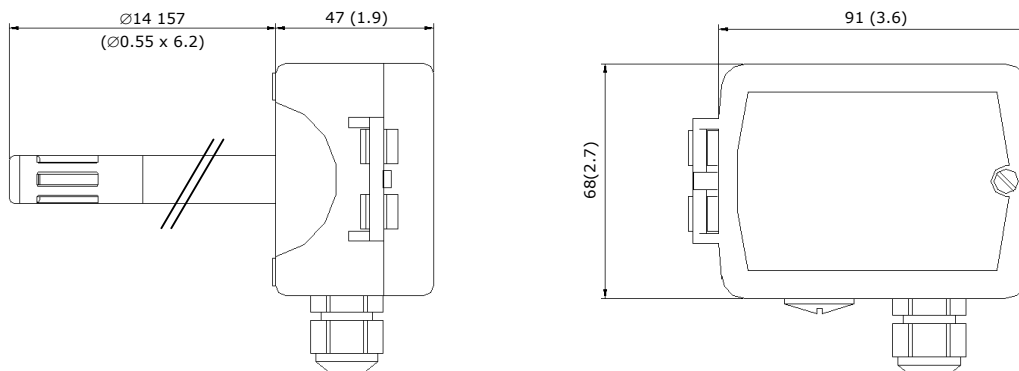

Mechanical design and installation

The unit consists of three parts: The back part with the probe, the flange and the cover.

Mounting location

The transmitter should be installed on the duct in an area where the air stream is well mixed:

- Locate a supply air sensor two or three meters downstream from the nearest fan and coil.
- Mount the return air sensor close to the air inlet but downstream from a return fan if one is present.

Installation

1. Drill a hole with a diameter of 16 mm (5/8") in the air duct.
2. For installation of the transmitter directly on the duct: Drill two smaller holes for the self-tapping screws diagonal on a diameter of 92 mm (3.6").
Tip: Use the housing as marking guide for the holes.
3. For installation of the transmitter with the flange: Drill two smaller holes for the self-tapping screws diagonal on a diameter of 60 mm (2.32"). Tip: Use the flange as marking guide for the holes.
4. Open the single screw on the cover and remove cover.
5. Connect the conductors to the terminals of the back part according to wiring diagram.
6. Insert the probe in the hole; secure the back part to the duct with two self-tapping screws. Pay attention to the airflow arrow on the label on the housing. The transmitter must be mounted in such a way that the holes on the side of the probe face the airflow. If mounting with a flange, make sure that the lowest hole is still inside the duct or else close the holes with a tape else there may be measurement errors.
7. While in the open position, slide the two hooks of the cover into the latch at the left side of the back part.
8. Close the front part.
9. With a Philips-type screw driver of size #2, carefully tighten the front holding screw to secure the cover to the back part. This screw is located on the front right side of the front part. There is no need to tighten the screw too much.

Connection terminals

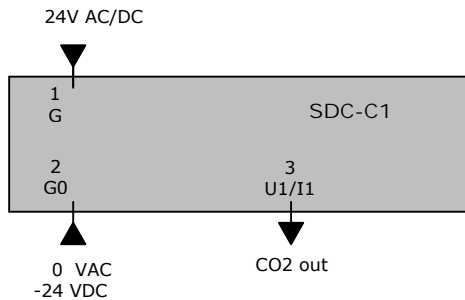

- 1: G Power supply 24 VAC, +24 VDC
 2: G0 Power supply 0 VAC, -24 VDC
 3: U1 JP1 = 1-2, voltage output of CO₂ transmitter 0...10 V or 2...10 V (JP3)
 3: I1 JP1 = 2-3, current output of CO₂ transmitter 0...20 mA or 4...20 mA (JP3)

Output signal configuration

The analog output signal type may be configured with a jumper for 0...10 VDC or 0...20 mA control signals. The jumpers are located next to the terminal connector of each analog output. See table below for jumper placement. The factory setting is to 0...10 VDC.

Signal Type	JP1
0...10 V	(1-2)
0...20 mA	(2-3)

The signal range may be set with JP3 for both analog outputs. JP3 will only operate if the output range specified with OP01 and OP02 is left at the default position of 0...100%. With any other setting the position of JP3 has no influence and the range defined with the output parameters applies.

Signal Range	JP3
0...10 V, 0...20 mA	(1-2)
2...10 V, 4...20 mA	(2-3)

Jumper settings

JP4 Calibration	
	Calibrate 0 ppm Provide CO ₂ free gas
	Calibrate 400 ppm Provide clean fresh air
	Standard position, No calibration

Status LED
LED indicates status No light: no power or unit damaged 5 sec blinking: Normal 2 sec blinking: OPA-S connected 1 sec blinking: Sensor element error if alternate in 2 sec interval with air quality LED: Calibration is active.

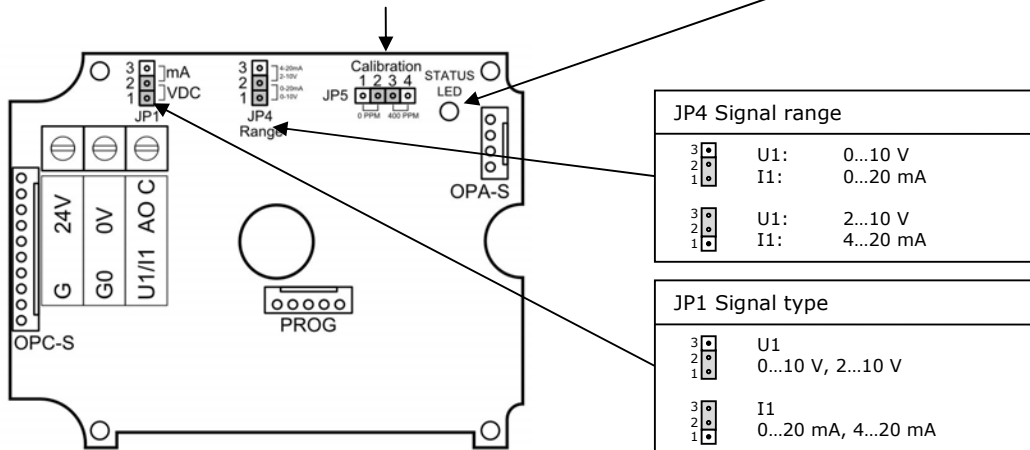

Use as P-controller

The CO₂-transmitter may be converted into a proportional fresh air controller through a simple change of two parameter settings:

Set a minimum concentration when the fresh air fan should start to run at its minimum speed, for example 700 ppm. Set this as the minimum value in IP03 parameter. Then define the value when the fan should run at full speed, for example 1500 ppm and set this value in IP04. Your transmitter has now been converted into an air quality P-controller! The fan will start to run if the CO₂ concentration is higher than 700 ppm. It increases to its maximum when CO₂ concentration reaches 1500 ppm.

Configuration parameters

The transmitter can be adapted to fit perfectly into any application by adjusting the software parameters. The parameters are set with the operation terminals OPC-S or OPA-S. The OPA-S may also be used as remote indicator. For correct display version 1.4 is required.

Input configuration

Parameter	Description	Range	Default
IP 00	Enable display of air quality LED on front	ON, OFF	ON
IP 01	Samples taken for averaging control signal	1...255	10
IP 02	Calibration	-10...10%	0
IP 03	Minimum CO ₂ range ppm (concentration when output is at its minimum)	0...9900 ppm	0 ppm
IP 04	Maximum CO ₂ range ppm (concentration when output is at maximum)	0...9900 ppm	2000 ppm
IP 05	Level for medium air quality (orange light)	0...9900 ppm	800 ppm
IP 06	Level for high air quality (red light)	0...9900 ppm	1500 ppm
IP 07	Enable ABC automatic background calibration	ON, OFF	ON

Output configuration

Parameter	Description	Range	Default
OP 00	AO1: CO ₂ : Configuration of output signal: 0 = Feedback CO ₂ input 1 = Feedback CO ₂ minimum value 2 = Feedback CO ₂ maximum value	0...2	0
OP 01	AO1: CO ₂ : Minimum limitation of output signal	0...Max %	0%
OP 02	AO1: CO ₂ : Maximum limitation of output signal	Min...100%	100%

Calibration

The default sensor OEM unit is maintenance free in normal environments thanks to the built-in self-correcting ABC algorithm (Automatic Baseline Correction). This algorithm constantly keeps track of the sensor's lowest reading over a 7 days interval and slowly corrects for any long-term drift detected as compared to the expected fresh air value of 400 ppm CO₂.

Rough handling and transportation might, however, result in a reduction of sensor reading accuracy. With time, the ABC function will tune the readings back to the correct numbers. The default "tuning speed" is however limited to about 30 ppm/week. For post calibration convenience, in the event that one cannot wait for the ABC algorithm to cure any calibration offset, jumper 3 is provided for the operator to choose calibration options. There are two calibration possibilities: 0 ppm and 400 ppm. Only one calibration needs to be performed.

Calibration to 0 ppm with CO₂ free gas

1. Connect the sensor on top with a tube (soft tubing 2x4 mm) and a nipple (nylon tubing 30x0.8x2.2 mm), see picture on the right side. There are 2 alternative positions for nipple attachment.
2. Let a gas mixture which is free from CO₂ (i.e. Nitrogen or Soda Lime CO₂ scrubbed air) flow into the sensor through the applied tube. The flow shall be in the range of 0...1.0 liter/minute during 3 minutes. Keep the gas mixture flowing during the whole procedure.
3. Set JP4 to position 1-2 for a minimum time of 8 seconds. The air quality LED will blink in green color alternating with the status led in 2 second intervals.
4. Replace JP4 to position 2-3 or remove completely.
5. Verify the zero calibration using the OPA-S or the analog outputs. They should show 0 ppm CO₂.
6. If zero calibration is not executed (sensor detected unstable gas concentration) wait 10 seconds and repeat steps 3 and 4 again. Do not breathe on the sensor!

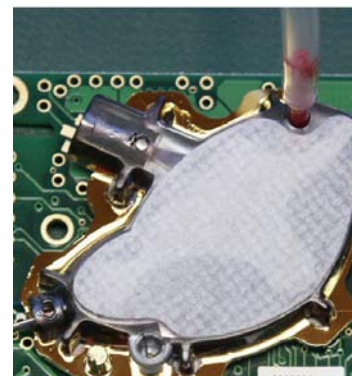

Calibration to 400 ppm (fresh air)

1. Expose the active sensor for at least 5 minutes to fresh outside air.
2. Place JP4 to position 3-4 for at least 8 seconds.
3. Replace JP4 to position 2-3 or remove completely.
4. Verify the calibration using the OPA-S or the analog outputs. They should show 400 ppm CO₂.
5. If unsuccessful, wait at least 1 minute before repeating the procedure again. Make sure that the sensor environment is steady and calm!