

## SRC-T1 Indoor Temperature Transmitter

### Features

- Indoor temperature measurement
- Minimum and maximum value memory
- 0...10V, 0...20mA or 2...10V, 4...20mA measuring signals selectable with jumpers
- Optional alternative signal ranges programmable
- Selectable averaging signal
- Optional external display (OPA-S)
- Status LED

### Applications

- Indoor temperature measurement in heating, ventilation and air conditioning applications.
- Recording of minimum and maximum values for critical environments
- Supervision of critical temperatures



### Temperature Transmitter

The transmitter measures the temperature by the use of a precision sensing element. The microprocessor samples the temperature once per second. It calculates an averaging signal over a preset number of seconds and generates an output signal based on lower and upper signal range values. Standard range is -40...60°C (-40...140°F) and 10 seconds average. The signal range and the averaging samples may be customized.

The output signal range and type may be customized by jumpers and if required by a programming tool. Standard signal ranges are 0-10VDC, 2-10VDC, 4-20mA and 0-20mA. These ranges can be set by jumpers. Other ranges can be set by using the external display and programming module. (OPA-S)

### Minimum and Maximum Values:

Using the programming tool, the user has the option to read out and reset minimum and maximum values. The minimum and maximum values may as well be used as output signals. The minimum and maximum values are saved into the EEPROM and are available after a power interruption.

### Ordering

Item Name	Item Code	Description/Option
SRC-T1	40-30 0058	Temperature transmitter
SRC-T1-W0	40-30 0058-0	<b>0 Temperature Range: -40...60°C (-40...140°F) (Default)</b>
SRC-T1-W1	40-30 0058-1	1 Temperature Range: -35...35°C (-31...95°F)
SRC-T1-W2	40-30 0058-2	2 Temperature Range: 0...50°C (32...122°F)
SRC-T1-W3	40-30 0058-3	3 Temperature Range: Special – Specify in order

### Accessories

Item Name	Item Code	Description/Option
OPA-S	40-50 0006	External display module

**Technical Specification**

Power Supply	Operating Voltage	24 V AC 50/60 Hz $\pm$ 10%, 24VDC $\pm$ 10%		
	Transformer	SELV to HD 384, Class II, 48VA max		
	Power Consumption	Max 2 VA		
	Terminal Connectors	For wire 0.34...2.5 mm <sup>2</sup> (AWG 24...12)		
Sensing Probe	Accuracy:			
	0...50°C (32...122°F): 50...60°C (122...158°F):	0.2 K 0.5 K		
	allow one hour after power up for compensation swing in			
Signal Outputs	Analog Outputs			
	Output Signal	DC 0-10V or 0...20mA		
	Resolution	10 Bit, 9.7 mV, 0.019.5 mA		
	Maximum Load	20 mA, 500 $\Omega$		
Environment	Operation	To IEC 721-3-3		
	Climatic Conditions	class 3 K5		
	Temperature	0...60°C (32...140°F)		
	Humidity	<95% R.H. non-condensing		
	Transport & Storage	To IEC 721-3-2 and IEC 721-3-1		
	Climatic Conditions	class 3 K3 and class 1 K3		
	Temperature	-40...70°C (-40...158°F)		
	Humidity	<95% R.H. non-condensing		
Standards	 conformity EMC Directive Low Voltage Directive	2004/108/EC		
		2006/95/EC		
	Product standards Automatic electrical controls for household and similar use	EN 60 730 -1		
	Special requirement on temperature dependent controls	EN 60 730 - 2 - 9		
	Electromagnetic compatibility for domestic and industrial sector	Emissions: EN 60 730-1 Immunity: EN 60 730-1		
	Degree of Protection	IP30 to EN 60 529		
	Safety Class	III (IEC 60 536)		
	General	Housing Materials	Cover	Fire proof ABS plastic
			Mounting Plate	Galvanized Steel
		Dimensions (H x W x D)	21 x 88 x 88 mm (0.8 x 3.5 x 3.5 in)	
Weight (including package)	160 g (5.6 oz)			

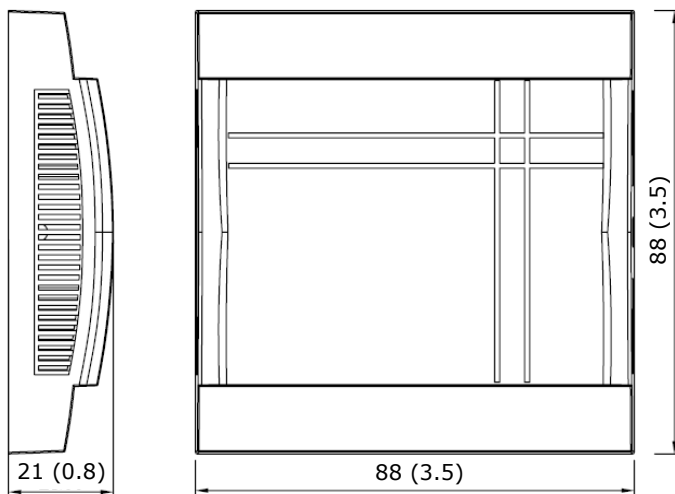
**Dimensions mm (inch)**

## Mechanical design and installation

The unit consists of two parts: (a) The mounting plate and (b) the cover with the transmitter.

### Mounting location

Mount the transmitter on a flat interior wall of the room to be controlled. Do avoid obstructions such as shelves, curtains and recesses. Do not place near heat sources, draft channels. Do not expose to direct sunlight.

### Installation

1. Open the single screw on the cover and remove cover from mounting plate.
2. Fix the mounting plate to the flush mounting box or the wall surface
3. Connect the conductors to the terminals of the back part according to wiring diagram
4. The end of the conduit at the sensor must be sealed to prevent false measurements due to draughts through the conduit.
5. Slide the two hooks on top of the cover into the two latches on top of the mounting plate.
6. Close the cover.
7. With a Philips-type screw driver of size #2, carefully tighten the front holding screw to secure the cover to the back part. There is no need to tighten the screw too much.

### Connection terminals

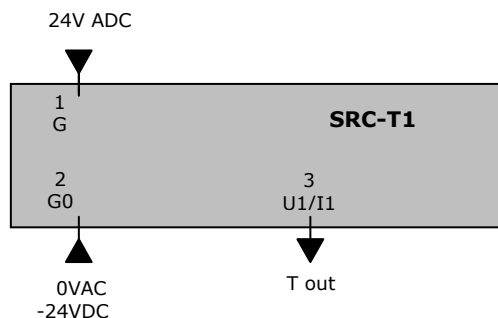

- 1: G Power supply 24VAC, +24VDC  
 2: G0 Power supply 0VAC, -24VDC  
 3: U1 JP1 = 1-2, voltage output of temperature transmitter 0...10V or 2...10V (JP3)  
 3: I1 JP1 = 2-3, current output of temperature transmitter 0...20mA or 4...20mA (JP3)

### Configuration parameters

The transmitter can be adapted to fit perfectly into any application by adjusting the software parameters. The parameters are set with the operation terminals OPA-S. The OPA-S may also be used as remote indicator.

### Input configuration

Parameter	Description	Range	Default
IP 00	TI1: Celsius or Fahrenheit, C = OFF, F = ON	ON, OFF	OFF
IP 01	TI1: Samples taken for averaging control signal	1...255	10
IP 02	TI1: Calibration	-10...10	0
IP 03	TI1: Minimum temperature	-40...215 °C/F	0 °C
IP 04	TI1: Maximum temperature	-40...215 °C/F	50°C

### Output configuration

Parameter	Description	Range	Default
OP 00	A01: Configuration of output signal: 0 = Feedback temperature input, 1 = Feedback temperature minimum value 2 = Feedback temperature maximum value	0 - 2	0
OP 01	A01: Minimum limitation of output signal	0 - Max %	0%
OP 02	A01: Maximum limitation of output signal	Min - 100%	100%

### Output signal configuration

The analog output signal type may be configured with a jumper for 0-10 VDC or 0-20 mA control signals. The jumpers are located next to the terminal connector of each analog output. See table below for jumper placement. The factory setting is to 0-10 VDC.

Signal Type	JP1
0 – 10 V	(1-2)
0 – 20 mA	(2-3)

The signal range may be set with JP3 for both analog outputs. JP3 will only operate if the output range specified with OP01 and OP02 is left at the default position of 0...100%. With any other setting the position of JP3 has no influence and the range defined with the output parameters applies.

Signal Range	JP3
0 – 10 V, 0 – 20 mA	(1-2)
2 – 10 V, 4 – 20 mA	(2-3)

### Jumper Settings

JP1 Signal type	
3 2 1	U1 0-10V, 2-10V
3 2 1	I1 0-20mA, 4-20mA

JP3 Signal range	
3 2 1	U1: 0-10V I1: 0-20mA
3 2 1	U1: 2-10V I1: 4-20mA

